

Instruction Manual



QUICK GUIDE

- Wiring Diagram
Page 2-5
- Programming
the Display
Page 14-
- Calibration
Chapter 6
- Troubleshooting
Chapter 7

Model 14 pH/Redox Transmitter

BROADLEY
TECHNOLOGIES

19 Thomas, Irvine, California 92618 USA
Call Toll-Free: 877.246.7900 (USA & Canada)
Phone: 949.452.1112 Fax: 949.452.1114
E-Mail: sales@broadleytech.com





Broadley Technologies Corporation

19 Thomas
Irvine, California 92618
USA

Corporate Headquarters:
Toll-Free: 877.246.7900
Tel: 949.452.1112 Fax: 949.452.1114
E-Mail: sales@biotechcatalog.com
Website: www.biotechcatalog.com

Copyright © 2000 Broadley Technologies Corporation
All Rights Reserved



Table of Contents

Chapter 1: Introduction	1-1
1.1 Introduction.....	1-1
1.2 pH Measurement	1-1
1.3 Redox Measurement	1-2
1.4 Main Features of the Instrument	1-2
1.5 Dimensions.....	1-3
Chapter 2: Installation of the Instrument.....	2-1
2.1 Unpacking the Instrument.....	2-1
2.2 Installation Requirements	2-1
2.3 Mounting Options	2-1
2.4 Electrical Connections	2-4
2.5 Terminal Descriptions.....	2-5
2.6 Power Connection.....	2-6
2.7 Measuring Line	2-6
2.8 Starting the Transmitter.....	2-6
2.9 Adjusting the Display Contrast.....	2-6
2.10 Changing the Programming Language.....	2-7
Chapter 3: Front Panel Display	3-1
3.1 Front Panel Keys	3-1
3.2 Displays 1 through 4.....	3-2
3.3 Description of the Function Keys.....	3-3
3.4 Icons.....	3-3
3.5 Enter or Modify a Value	3-4
Chapter 4: Programming the Instrument.....	4-1
4.1 Main Menu	4-1
4.2 CALIBRATION Menu	4-2
4.3 MAINTENANCE Menu	4-3
4.4 PROGRAMMING Menu	4-4
4.4.1 MEASURE Menu.....	4-5
4.4.2 ALARMS Menu	4-7
4.4.3 CONTROLLER Menu.....	4-10
4.4.4 mA OUTPUTS Menu	4-12
4.4.5 RS485 Menu	4-13
4.5 SERVICE Menu	4-15
4.5.1 IMPEDANCES Menu	4-17
4.5.2 AVERAGE Menu	4-17
4.5.3 DISPLAY Menu	4-18
4.5.4 CODE Menu	4-19
4.5.5 SOFT ISSUE Menu	4-20



Table of Contents (Continued)

Chapter 4: Programming the Instrument (continued)	4-1
4.5 SERVICE Menu (continued)	4-15
4.5.6 DEFAULT VALUES Menu	4-20
4.5.7 ADJUST mA Menu	4-21
Chapter 5 : Redox Programming	5-1
Chapter 6: pH Calibration	6.1
6.1 Calibrating the Instrument	6-1
6.2 Temperature Calibration	6-2
6.3 pH Calibration	6-3
6.3.1 Two-Point Calibration	6-4
Chapter 7 : Error Messages	7-1
Chapter 8 : Impedance measurement	8-1
8.1 Electrode Impedance	8-1
8.2 Measurement Principle	8-1
Appendix 1: Technical Specifications	A-1
Appendix 2: Default Values	B-1
Appendix 3: Temperature Conversion Chart	C-1



Chapter 1: Introduction

1.1 Introduction

The Model 14 pH/Redox transmitter has been designed for measuring and continuously controlling pH or redox potential and temperature in industrial process.

1.2 pH Measurement

Theory

The pH of a solution is the measurement of the acidity, or alkalinity of that solution. It is determined by the negative logarithm of the hydrogen ion activity: $\text{pH} = -\log_{10} a_{[\text{H}^+]}$

Two electrodes, glass electrode and a reference are used to measure pH. The glass electrode acts as a transducer, converting chemical energy (the hydrogen activity) into an electrical energy (measured in millivolts). The reaction is balanced and the electrical circuit is completed by the flow of ions from the reference solution through the measured solution.

The electrode and reference solution together develop a voltage (emf) whose magnitude depends on four things:

- the type of reference electrode
- the internal construction of the glass electrode
- the pH of the solution
- the temperature of the solution.

This electrode voltage is expressed by the Nernst equation:

$$E = E_0 - (2.3 R I) \log a_{[\text{H}^+]}$$

$$E = E_0 - (\text{slope}) \log a_{[\text{H}^+]}$$

Where:

E = the emf of the cell

E_0 = the zero potential (isopotential) of the system: depends on the internal construction of the glass and

reference electrodes

R = gas constant

T = temperature in Kelvin

$a_{[\text{H}^+]}$ = activity of the hydrogen ion (assumed to be equivalent to the concentration of hydrogen ions)

F = Faraday constant

For every unit change in pH (or decade change in ion concentration) the emf of the electrode pair changes by 59.16 mV at 25°C. This value is known as the *Nernstian slope* of the electrode.

The pH electrode pair is calibrated using solutions of known and constant hydrogen ion concentration, called buffer solutions. The buffer solutions are used to calibrate both the electrode's isopotential and slope.

1.3 Redox Measurement

A redox measuring system consists of a redox and a reference electrode. The measured redox potential is the ratio of electrode activities and the number of transferred electrons. In many cases the pH of the solution will influence the potential, too.

The half-cell potential e_B , of the reference electrode will strongly influence the potential E of the measuring chain. To remove this influence the potential of the measuring electrode can be related to the hydrogen electrode. If e_B is the half-cell potential of the reference electrode used, the calculation is made by

$$e_{(\text{H})} = E + e_B$$

Such standardized redox potentials provide information to some extent on the oxidizing or reducing power of a redox system. Increasing positive values express an increasing power of oxidation. The more negative the potential, the stronger the reducing power will be. The range of practical interest is between +1500 and -1000 mV. Standard potentials of a redox system will be found



for $a_{Ox} = a_{Red}$ and for $pH = 0$ which correspond to a standardized hydrogen ion activity $a_{[H^+]} = 1$ mole per liter. The stability and reversibility of a redox system strongly influence the reproducibility of the measured redox potential.

1.4 Main Features of the Instrument

The Model 14 is equipped with a single input measurement channel: a pH or redox sensor may be connected in addition to a temperature Pt100 or Pt1000 probe.

Sensor interrogation is a standard feature on the Model 14. To utilize this function, the pH electrode should be equipped with a ground. The Model 14 is also equipped with 2 analog outputs (0 – 20 mA).

Specifications (see Appendix 1 for detailed specifications):

- Power Supply
- Standard version :
- 90.265 VAC 50/60 Hz
 - Low voltage version :
- 13 – 30 VAC 50/60 Hz
- 18 – 42 VDC

Consumption	25 VA
Measuring Ranges	pH : 0 – 14 ORP (redox) : ± 1500 mV temperature : -20 – 200°C (-4 – 392°F)
Connections	2.5 mm ² screw terminal pulled-out for the relays and power supply
Weight	2 kg
Package	Includes instruction manual, 4 cable glands, 2 fittings and 2 mounting screws
Conformance to European Electrical Standards	EN 50081-1 & EN 50082-2(RFI) EN 61010-1 (low voltage directive)
Maintenance	No particular maintenance required. Clean the instrument with a soft tissue. Do NOT use any aggressive agent.



1.5 Dimensions

(Dimensions are in mm [inches]).

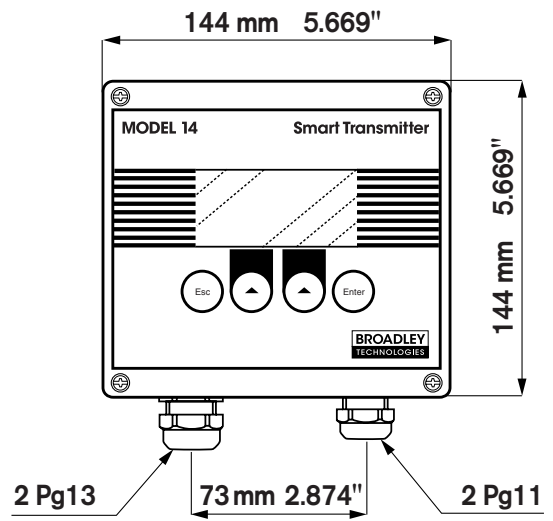
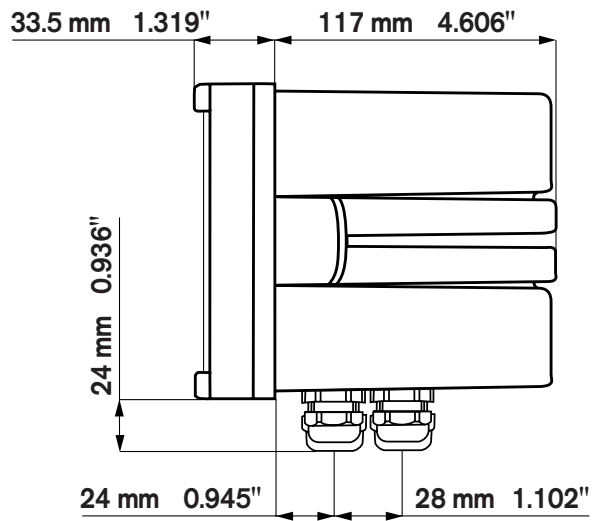





Chapter 2: Installation of the Instrument

2.1 Unpacking the Instrument

The analyzer should be unpacked with great care. Watch for any loose accessories. Confirm the instrument includes: instruction manual, certificate of conformity, 4 cable glands, 2 fittings and 2 mounting screws.

The analyzer has been factory-checked and tested prior to shipment. It is advisable, however, to inspect all parts immediately upon receipt for any damage which may have occurred during shipment. A damaged shipping container may indicate internal damage, which may not be immediately obvious. If there is any evidence of damage, keep the shipping container and refer to your local agent or to:

Broadley Technologies Corporation
19 Thomas
Irvine, CA 92618 USA
877-246-7900

2.2 Installation Requirements

The analyzer should be located in a site, which permits access for inspection or maintenance operations. Choose a site which meets the following criteria:

- No excessive vibrations
- Away from direct sunlight or other outdoor exposure
- Ambient temperature and humidity are within specifications

Note: It is preferable to mount the instrument above eye level, allowing unrestricted view of the front panel displays and controls.

2.3 Mounting Options (using the red clamping bow)

The transmitter housing conforms to norm DIN 43700.

CAUTION!

Mounting should be done by qualified service personnel only. No power should be applied until the installation is complete.

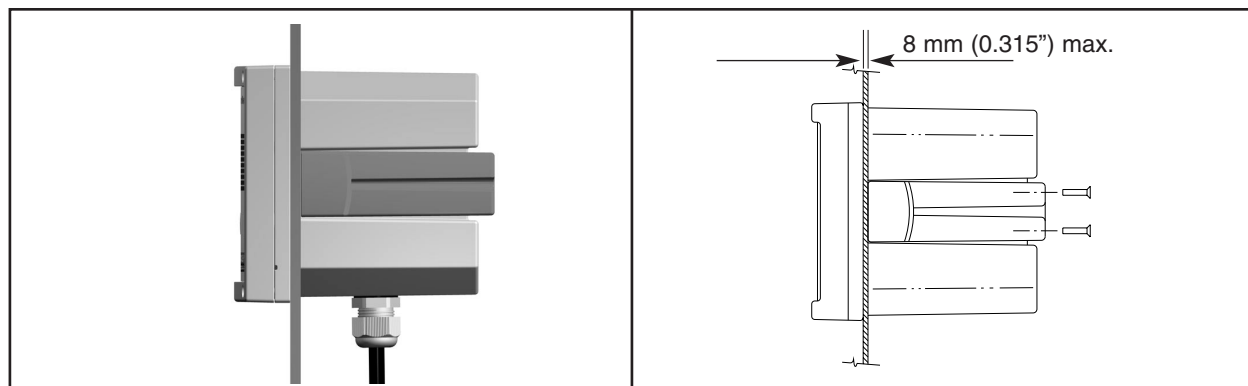

Panel mounting

Panel cutout: 138 mm x 138 mm (5.4" x 5.4")

Front panel dimensions: 144 mm x 144 mm (5.7" x 5.7")

Included hardware: 2 flat head screws, 4 mm x 18 mm long, for panels up to 6 mm thick

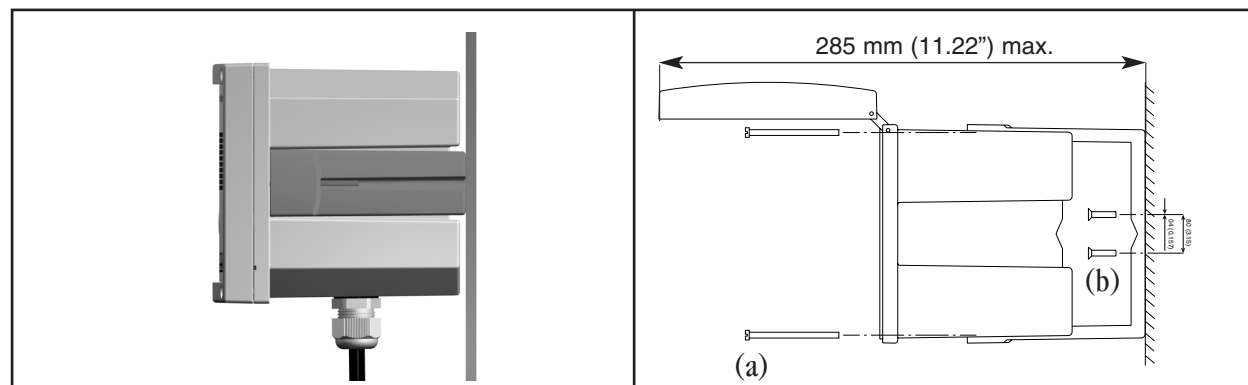

Wall mounting

Included hardware: (a) 2 pan head screws, 4 mm x 60 mm long for red clamping bow

Additional required hardware: (b) 2 flat head screws, 4 mm x 60 mm long

80 mm (3.15") on center



Vertical pipe mounting

Included hardware: 2 pan head screws,
4 mm x 60 mm long for red clamping bow



Horizontal pipe mounting

Included hardware: 2 pan head screws,
4 mm x 60 mm long for red clamping bow

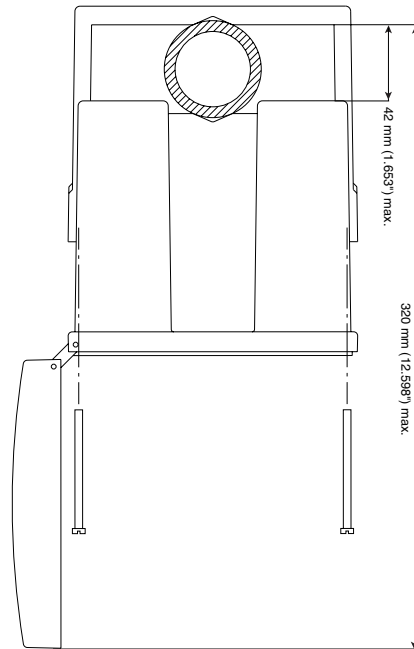
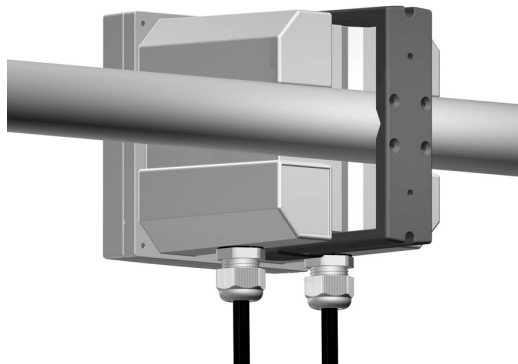

2.4 Electrical Connections

■ Model 14

Do not switch the instrument on until completion of the installation.

An aluminum armor plate inside the Model 14 gives a detailed description of the different terminals and their connections:

⇒ The Relay and Main Power terminals represented on the right side are accessible by removing the aluminum plate.

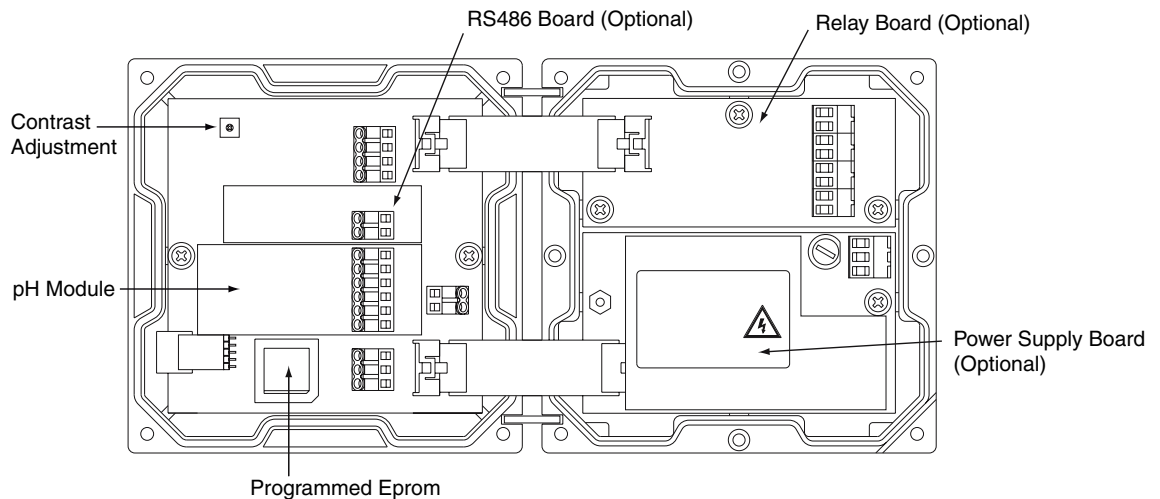
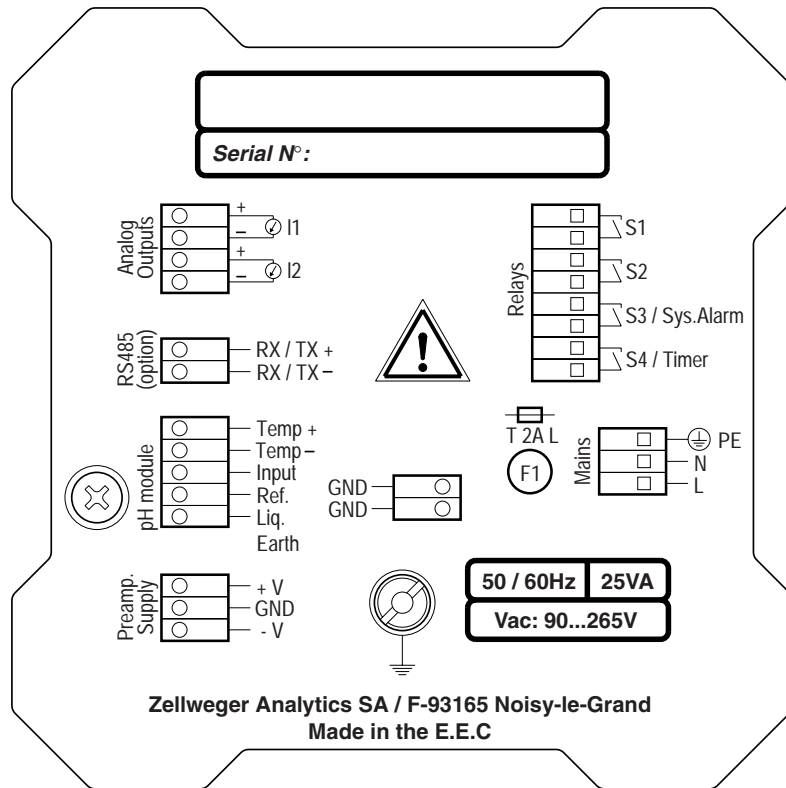

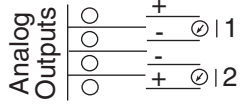
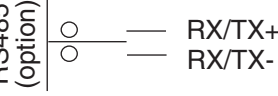
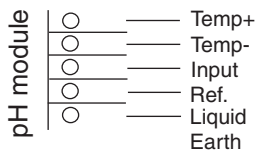
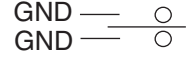
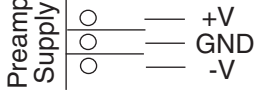
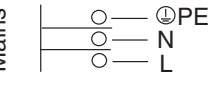
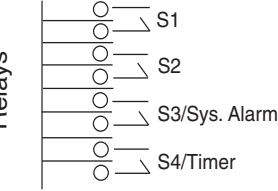

2.5 Terminal Descriptions

0/4 - 20 mA outputs galvanic insulation 	Description		Connection
	0 - 20 mA or 4 - 20 mA (n°1) [+]		user
	0 - 20 mA or 4 - 20 mA (n°1) [-]		user
	0 - 20 mA or 4 - 20 mA (n°2) [-]		user
	0 - 20 mA or 4 - 20 mA (n°2) [+]		user
RS485 (option) 	RS485 Option		user
			user
pH module 	Description	Color	Connection
	Temperature sensor [+]	black	temp +
	Temperature sensor [-]	blue	temp -
	Input	Clear	pH
	Ref.	red	Reference
	Liquid Earth		N.C.
GND 	Internal shield	brown	Ground
Preamplifier Supply 			N.C.
Behind aluminum plate			
Mains 	Main power supply, 90–265 VAC 50/60 Hz or 24 V AC/DC (special version)		Green (Ground)
			White
			Black
Relays 	Description		Connection
	Alarm 1, simple contact		user
	Alarm 2, simple contact		user
	Alarm 3 or alarm system, simple contact		user
	Alarm 4 or timer, simple contact		user

- ⇒ Electrical connections should remain dry to ensure proper operation of the instrument. Check the creeping of the cables when opening the transmitter.
- ⇒ It is required to use shielded cables. This shielding should be connected to the earth central shielding.



2.6 Power Connection

For safety reasons, it is required to observe the precautions below:

1. The instrument should be connected to the power supply by means of a breaker located close to the instrument and clearly identified.
2. This breaker should switch off phase and neutral in case of electrical problems or to service the instrument. However, the earth ground must always be connected.



Before servicing the instrument, confirm the power supply is “off”.

2.7 Measuring Line

The Model 14 transmitter should be connected to an electrode via a shielded cable.

2.8 Starting the Transmitter

Before switching on the transmitter, make sure the site voltage corresponds to the instrument voltage indicated on the identification plate. The electrode must be immersed in the measuring sample or a buffer solution before measuring.

2.9 Adjusting the Display Contrast

If the display contrast is not sufficient, adjust the potentiometer P1 (blue color, see figure on page 2-4), which is located on the top left of the CPU board (after opening the enclosure).



2.10 Changing the Programming Language

The default programming language is English. To change the language, follow the procedure below (example for French):

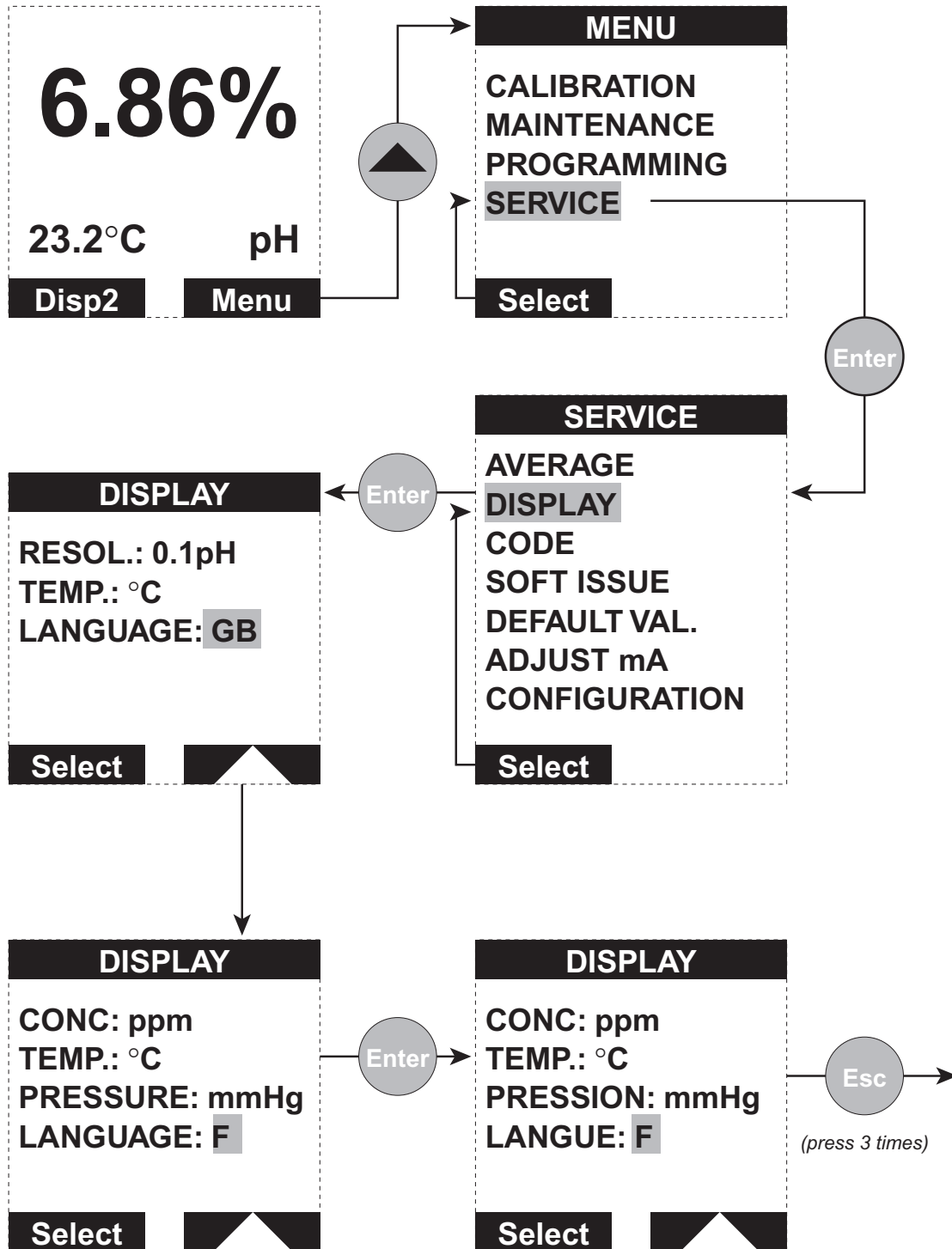





Chapter 3: Front Panel Displays

3.1 Front Panel Keys



Figure 3-1 : Front panel



3.2 Displays 1 to 4 (live displays)

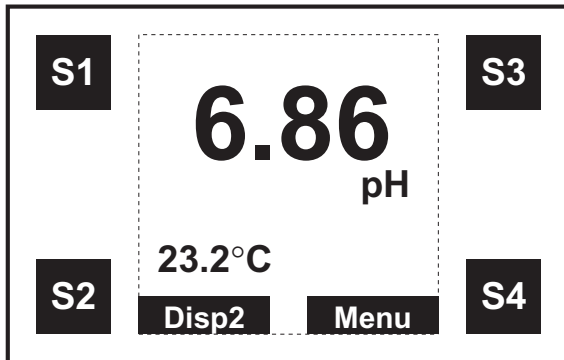

6.86% : pH measurement
(or MV for redox)

23.2°C : temperature measurement
S1...S4 : alarm status
(invisible if alarm is inactive)

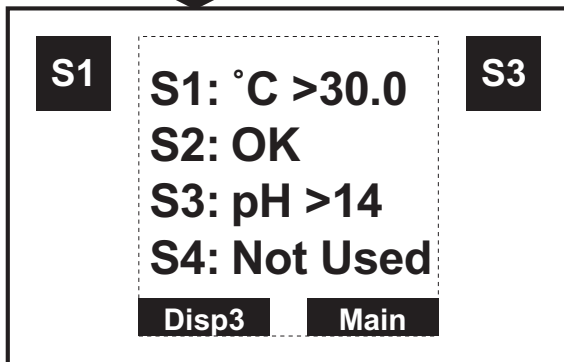

S1...S4 : alarm status
In this case relays S1 and S3 are active

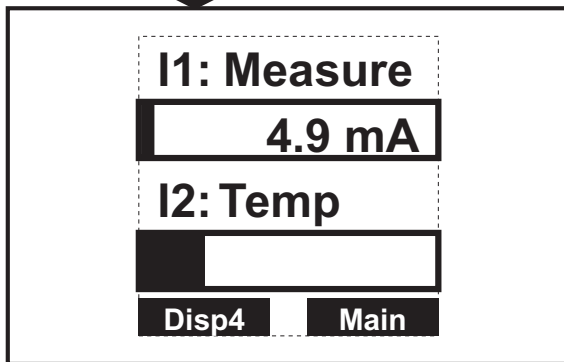



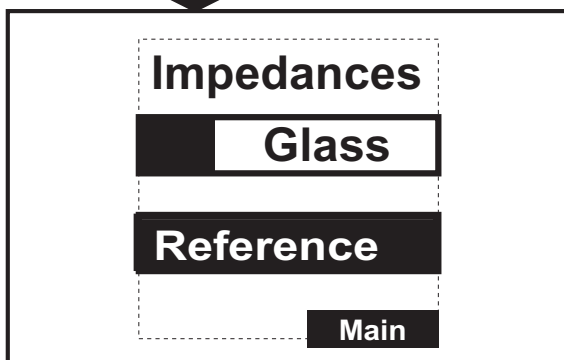









Analog output allocation and level.
Displays output value with a bargraph
and numeric indication.



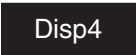





3.3 Description of the Function Keys

The function keys vary depending on the menu. Each of the function keys below will be highlighted at the bottom of the screen :

	Modify a parameter
	Choose a menu
	Go back to the main display
	Display the main menu
	Display screen 2
	Display screen 3
	Display screen 4
	Validate the measurement during calibration
	Confirm a command
	Increase a value
	Decrease a value
	Action on relay S1
	Action on relay S2

3.4 Icons

	Symbol of waiting or instrument reset
	Alarm system for relay S3
	Timer Symbol : countdown for relay S4
	Controller Symbol



3.5 Enter or Modify a Value

The highlighted digit can be modified with the key . Each digit can be validated by pressing ENTER. Repeat both operations for each digit.

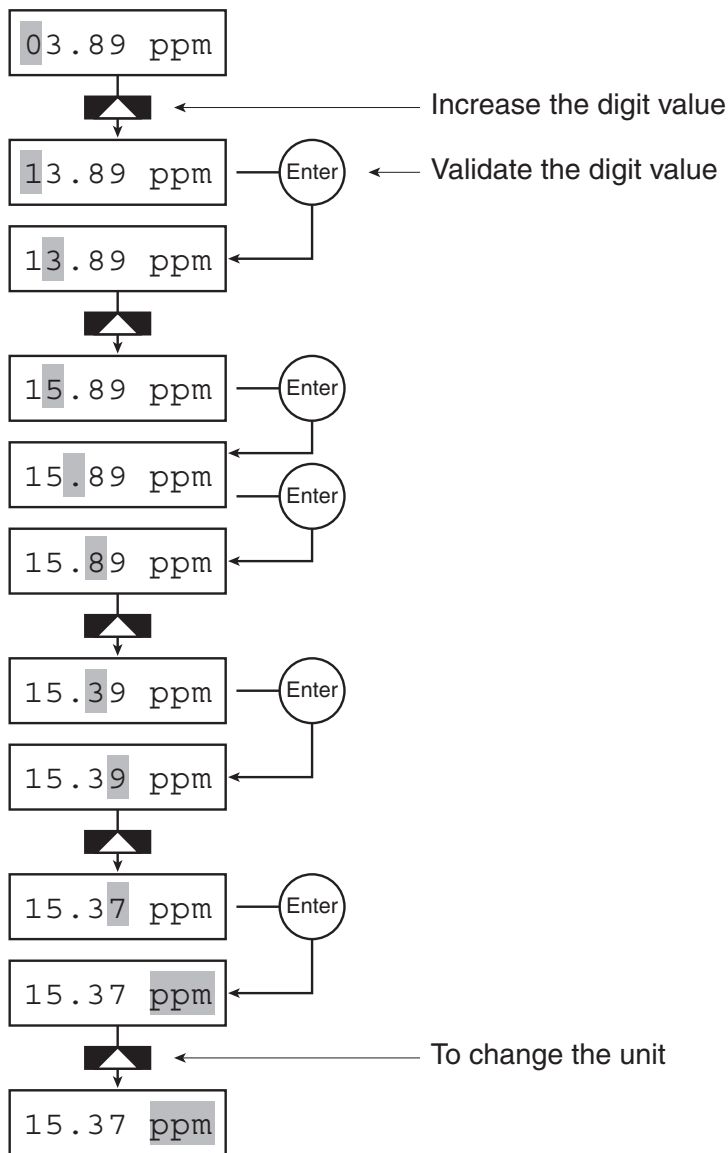

It is possible to display a negative first digit “-”

Note 1: If a menu is not accessed for at least 10 minutes, the instrument returns to the measuring mode except during the calibration and maintenance mode.
Note 2: An access code may be required for the CALIBRATION, PROGRAM and SERVICE menus (see page 4-19).



Chapter 4: Programming the Transmitter

4.1 Main Menu

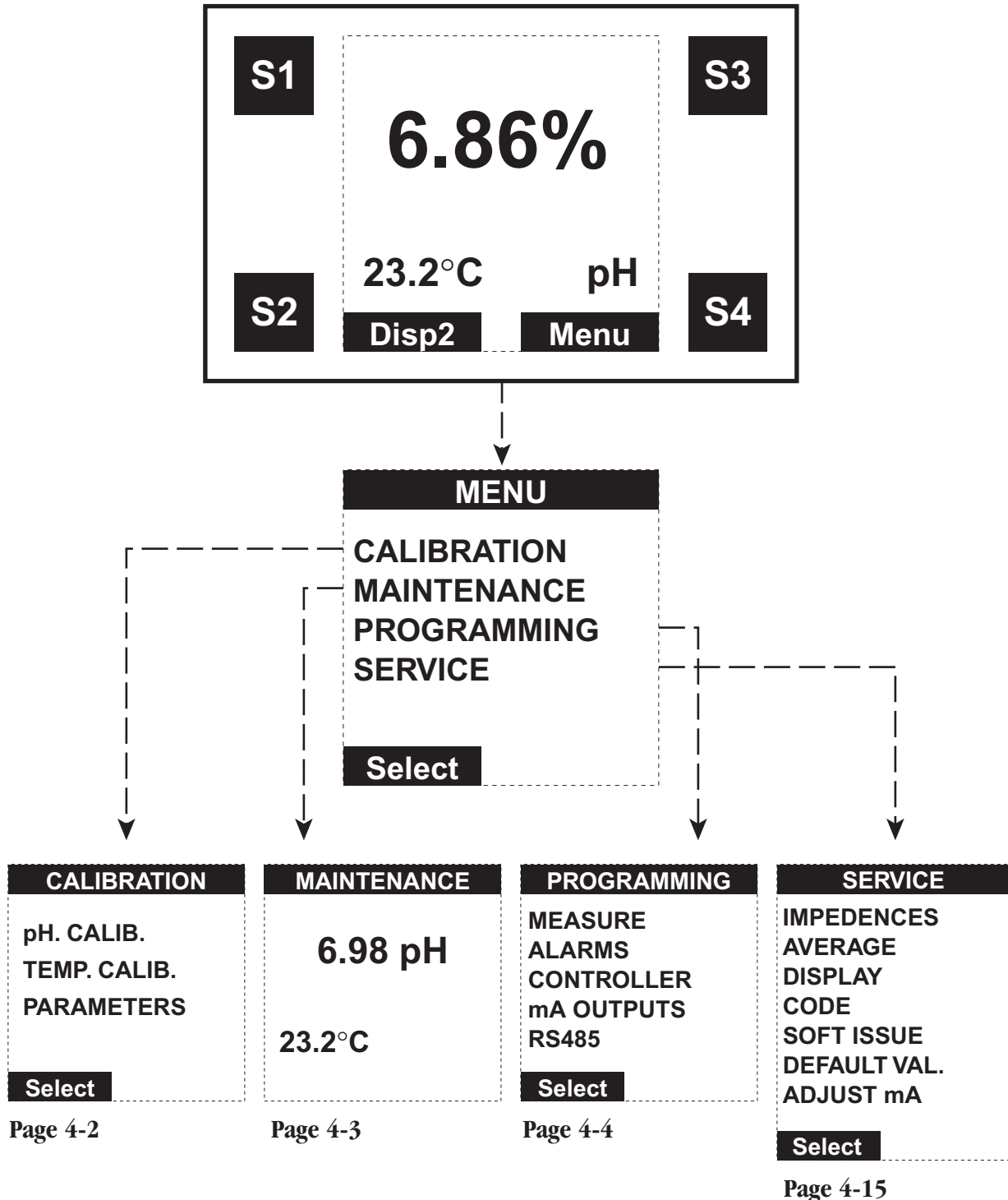

4.2 CALIBRATION Menus

Before any calibration, confirm that the parameters are correctly configured in the MEASURE Menu, page 4-5. All calibrations should follow the procedures below:

1. Configure the calibration characteristics in the "PROGRAMMING" menu.
2. Perform the calibration via the "EXECUTION" menu.



An access code may be required if it has been programmed. See page 4-19 for CODE menu. Some menus may or may not appear depending upon how some parameters may have been programmed.

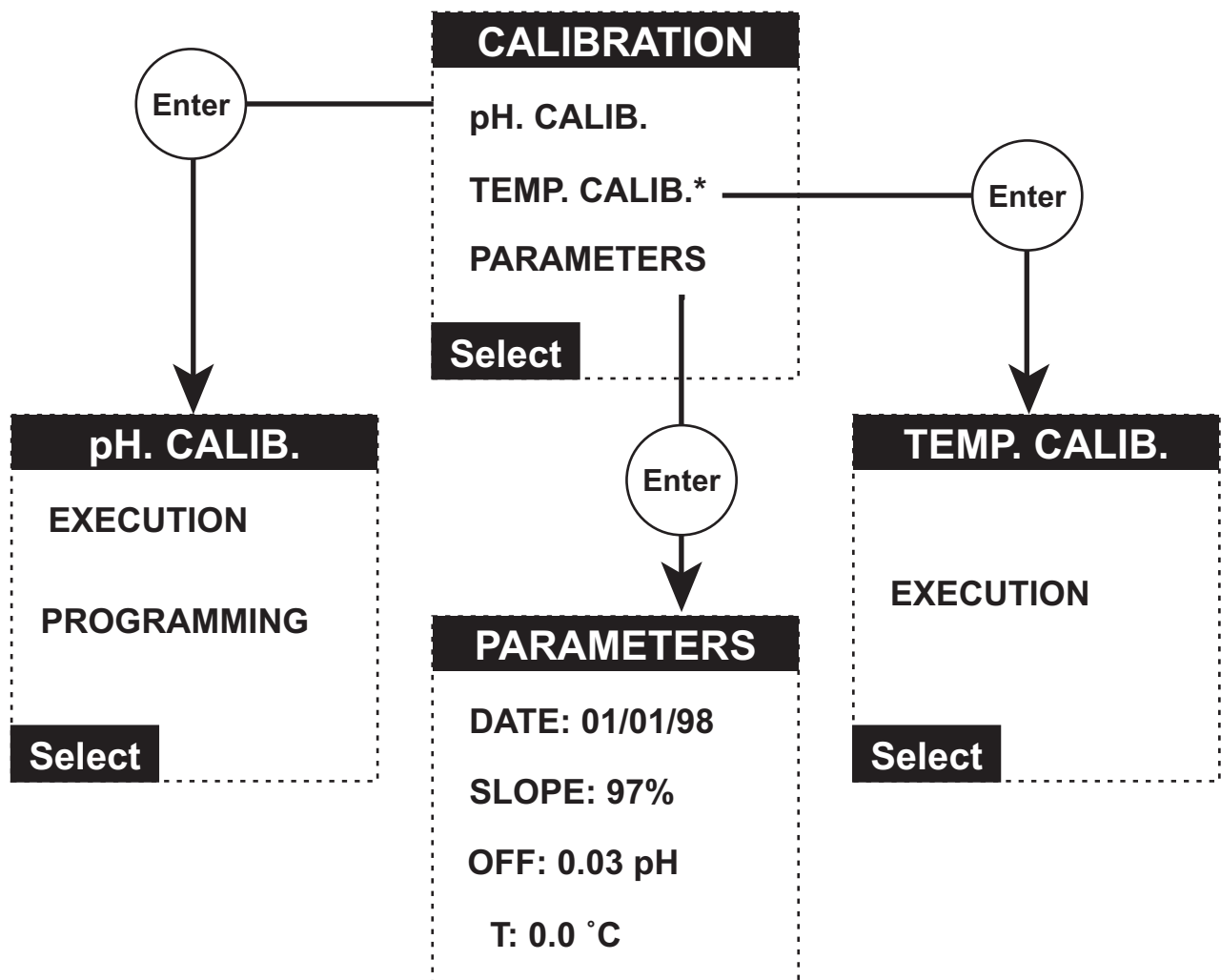

* This menu is displayed only if the Pt100/Pt1000 temperature measurement has been selected.



Parameters		
Date	mm/dd/yy	Date of last calibration. This must be updated manually.
SLOPE	XX.X%	The slope of the sensor
Off.	X.XX pH	The sensor offset

4.3 MAINTENANCE Menu

<div style="background-color: black; color: white; padding: 2px; text-align: center; font-weight: bold;">MAINTENANCE</div> <div style="text-align: center; margin-top: 10px;"> <p style="font-size: 24pt; font-weight: bold;">6.98 pH</p> <p style="font-size: 24pt; font-weight: bold;">21.6 °C</p> </div>	<p>Used for any maintenance operation in the instrument. The transmitter continues to display the variables measured.</p> <div style="background-color: black; color: white; padding: 5px;"> <p>The relay status is not modified. The analog output value depends on the configuration in the mA OUTPUTS/SPECIAL PROG. /MAINTENANCE menu.</p> </div>
---	--



4.4 PROGRAMMING Menu



An access code may be required.
See page 4-19 for CODE menu.

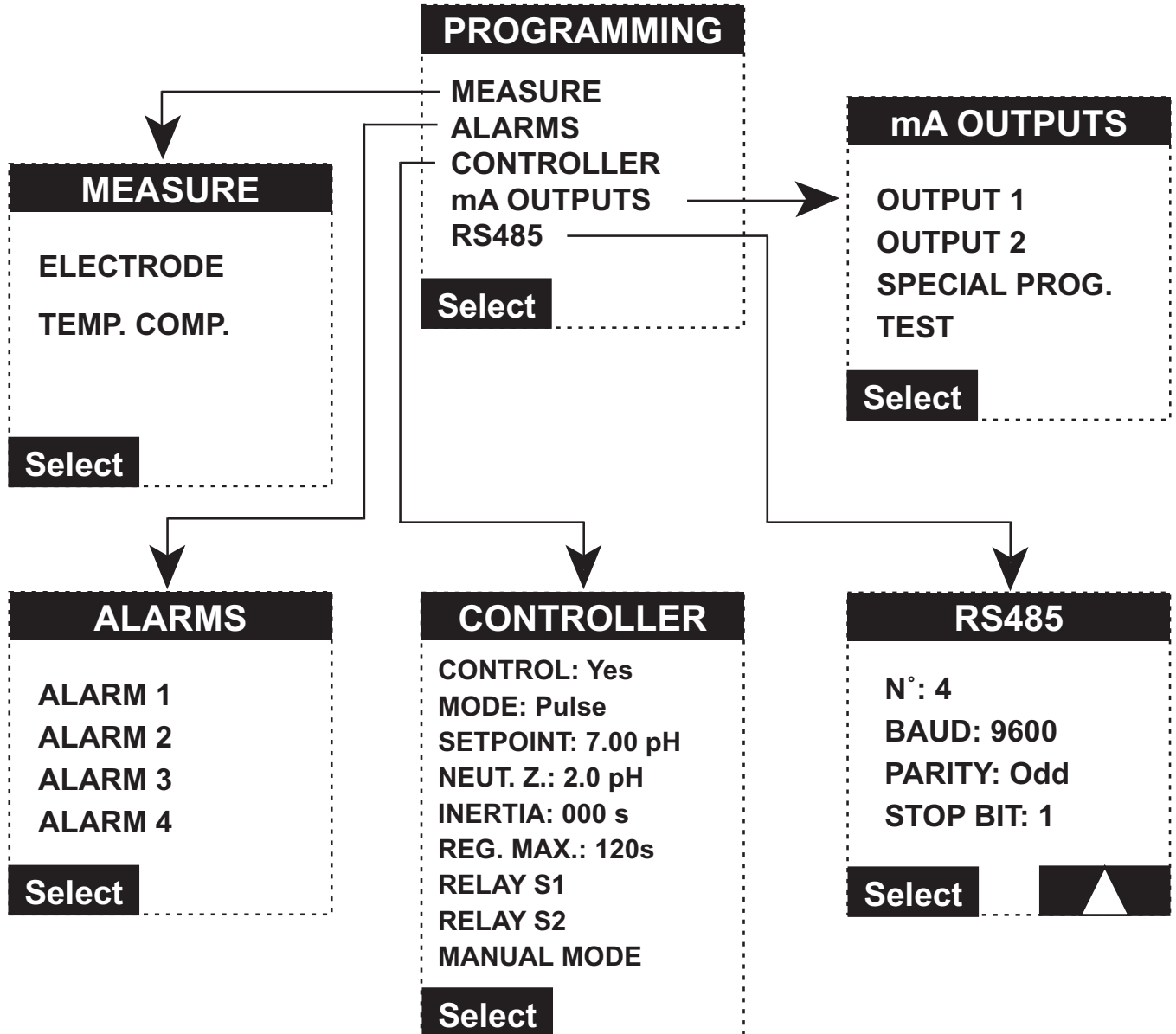



4.4.1 MEASURE Menu

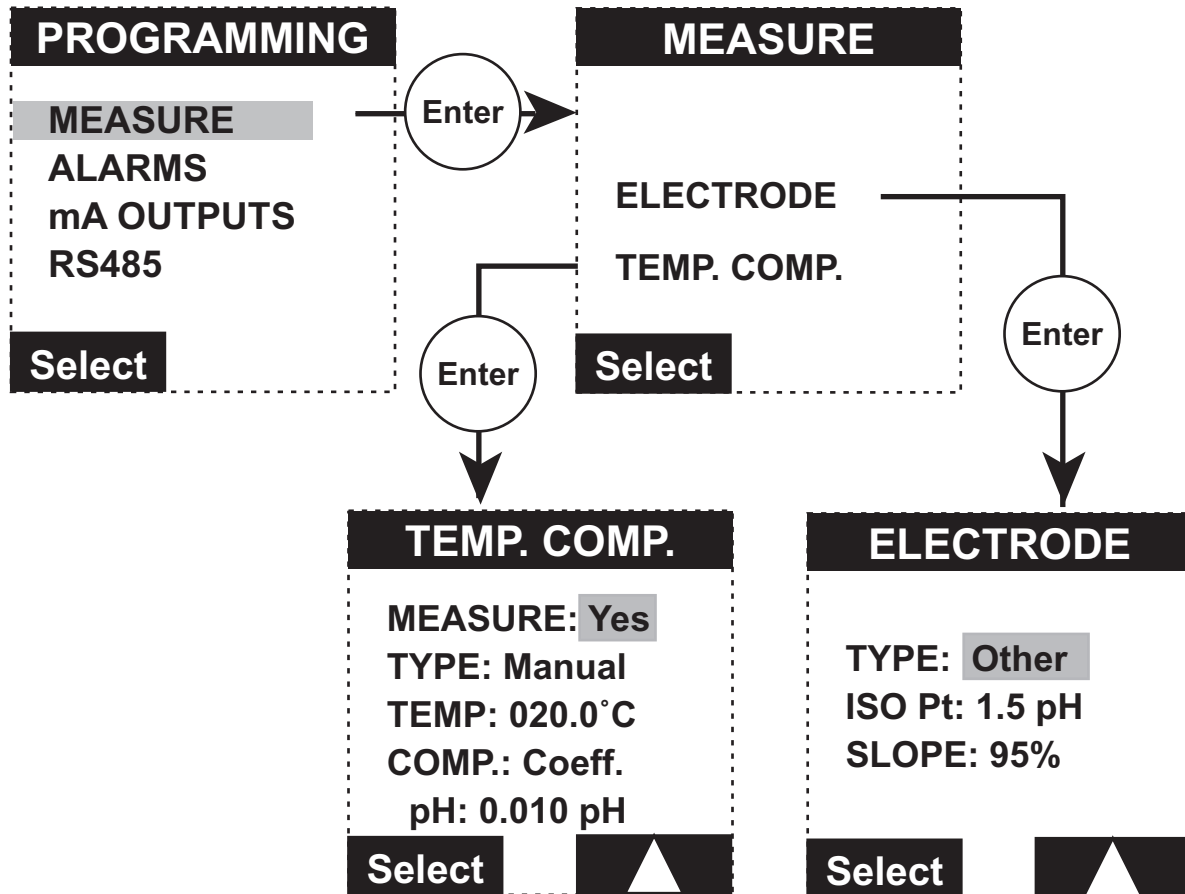

Electrode	
TYPE	Select electrode Glass, Antimony, Redox, Other
iso Pt	The iso thermal point corresponds to the pH value which does not vary according to the temperature
Slope	Indication of the electrode sensitivity in % for the theoretical value (59.15 mV/pH at 25°C)



Temperature Compensation		
MEASURE	-No -Yes	Select temperature measurement with or without a Pt100/Pt1000
TYPE	-Auto -Man	Choose automatic or manual temperature compensation
TEMP.	-XX.X °C	Enter the sample temperature during manual compensation
COMP.	-NERNST -Pure -Matrix 1 -Matrix 2 -Matrix 3 -Matrix 4 -Coeff.	Choose the type of curve to be used to calculating temperature compensation <ul style="list-style-type: none"> • linear compensation (0.198 mV/°C) • Ultrapure water curve • Sulfate Curve (4.84 mg/l corresponds to a pH 4.0 at 25°C) • Ammonia/Hydrazine Curve (0.272 mg/l ammonia + 20µg/l corresponds to a pH 9.0 at 25°C) • Ammonia/Morpholine/Hydrazine Curve (1.832 mg/l ammonia + 10 mg/l morpholine + 50µg/l hydrazine corresponds to a pH 9.6 at 25°C) • Phosphate Curve (3 mg/L phosphate + 0.3 mg/l ammonia) • Adjustable coefficient (pH/10°C)
ΔpH	-XX.XXX	In the case of programmable coefficient, enter the value of the coefficient (value in pH/10°C or pH/18°F)



4.4.2 ALARMS Menu

Relays S1 through S4 may be allocated to the limit, alarm system or timer functions.



When the controller function is activated, Alarms 1 and 2 are neither displayed nor accessible. See page 4-10 for CONTROLLER menu.

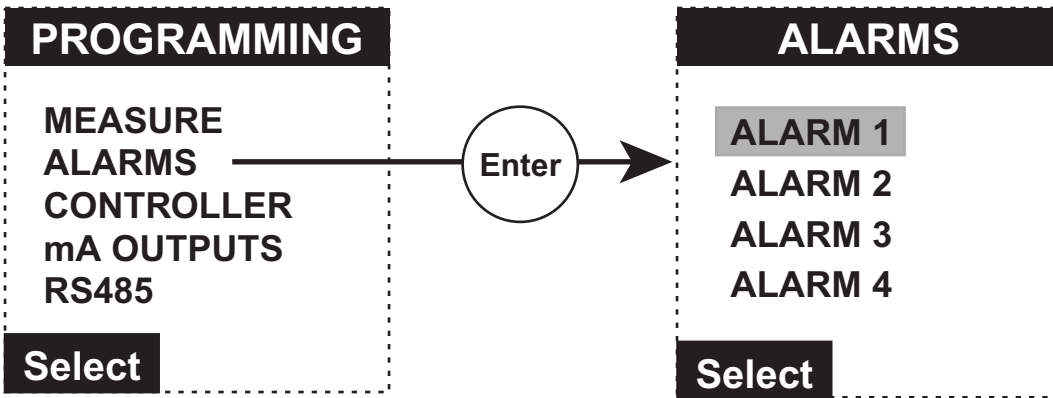

⇒ LIMIT FUNCTION:

The alarm relays are activated when the comparison between the measured value and the programmed limit meets the alarm function condition (up or down). The limits are programmed according to the following programming variables:

Limit Alarms			
<div style="border: 1px solid black; padding: 5px;"> <p>ALARMS</p> <p>AFFECT.: °C LIM.: 203°C DIR.: Down DELAY: 000s HYST.: 00% RELAY: NO</p> <p>Select </p> </div>	AFFECT	-No -pH -°C	Program limit on pH or temperature measurement or not activated
	LIM	xxx.x °C	Enter a limit value
	DIR.	-Up -Down	Choice of the limit direction
	DELAY	xxxx	Time before the relay is executed (in seconds)
	HYST.	xx%	Definition of the hysteresis limit in % (10% max.)The hysteresis operates on only one side of the limit. The hysteresis is below the limit for the high alarm (up) and above the limit for the low alarm (down).
	RELAY	-NO -NC	Relay normally open or normally closed



⇒ **SYSTEM ALARM FUNCTION:**

Relays S3 and S4 may be used as a fault indicator. To control the faults traced by the analyzer, connect the appropriate relay to an external alarm system. The relay is activated as soon as a default appears.

In case of a manual acknowledgment, the relay remains activated even if the default disappears. Press ENTER to deactivate the relay and the error message. In the case of an automatic acknowledgment, the relay and the error message are deactivated when the default disappears.

Alarm System			
<div style="border: 1px dashed black; padding: 5px;"> <p style="text-align: center;">ALARM 3</p> <p>MODE: System</p> <p>ACCEPT.: Auto</p> <p>RELAY: NC</p> <p>Select </p> </div>	MODE	-No -Limit -System	Alarm S3 may be programmed as a limit on the measurement (see paragraph above) or as an alarm system function
	ACCEPT	-Auto -Manu	In the case of an alarm system, choose between a manual (key ENTER) or an automatic acknowledgment
	RELAY	-NO -NC	The alarm relay can be normally open or normally closed



⇒ **TIMER FUNCTION:**

The S4 relay may be configured to a timer function.

Note: The measurement cycle lasts 4 seconds.			
<div style="border: 1px dashed black; padding: 5px;"> <p style="text-align: center;">ALARM 4</p> <p>MODE: Timer INTERV: 1440mn IMPUL. Nb.: 5 Ton: 005s Toff: 003s TmA: 05mn</p> <p>Select </p> </div>	MODE	-No -Limit -Timer	The Alarm 4 may be a limit (see parameters above) or a timer function for probe cleaning with Alarm 3
	INTERV	XXXX	Interval between 2 active cycles (in minutes)
	IMPUL. Nb.	X	Number of pulses during a cleaning cycle
	Ton	XXXs	Adjustment of the relay active time (in seconds) for each pulse
	Toff	XXXs	Adjustment of the relay inactive time (in seconds) for each pulse
	TmA	XXmn	Hold time for the analog outputs after each cycle ⇒ <i>The analog output status depends on the configuration of the menu mA OUTPUTS/SPECIAL PROG./TIMER</i>

4.4.3 CONTROLLER Menu

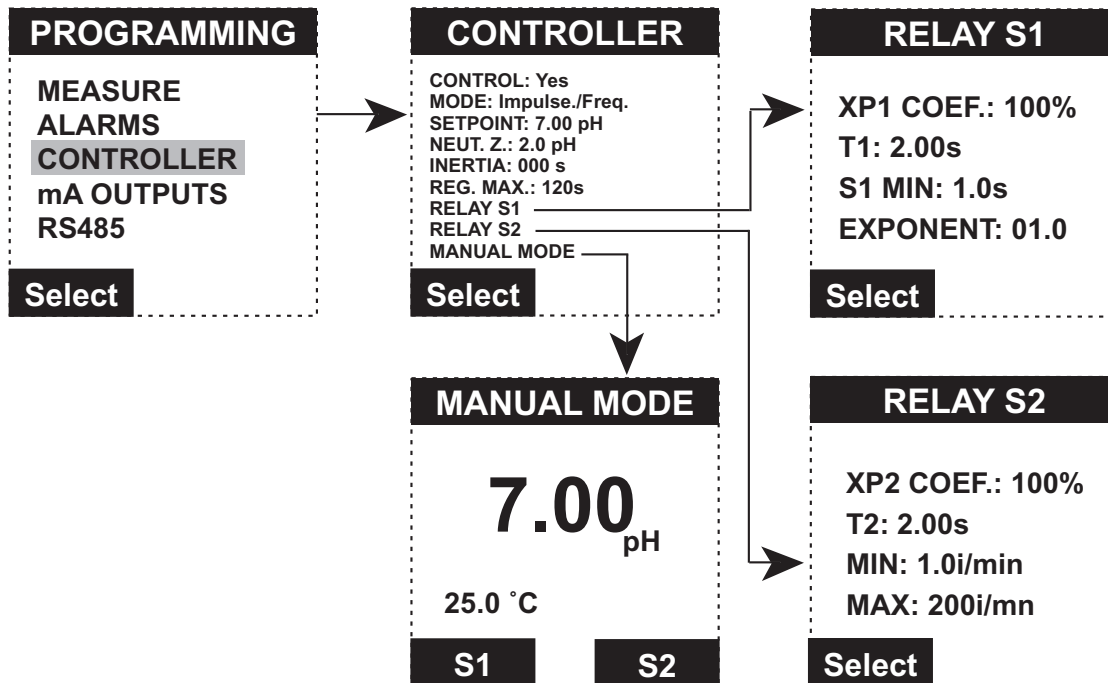

The controller output (Y) activates the limit switch relays. The Y value may correspond to a control by impulse of a control by frequency. The Y value is determined by the parameters below:

A setpoint W corresponds to the pH value to control A neutral zone (ZN) may be programmed and positioned symmetrically $\pm 50\%$ about the setpoint. Within this neutral band the control element is always inactive.

A proportional band (XP) represents the regulation slope. An XP value equal to 100% is defined as a Y controlling value of 100% for a 5 pH (or 1000mV in redox) drift according to the neutral zone extremity. The value of Y in pH corresponds to the equation below:

$$Y = \frac{100}{XP} * \frac{pH - (W + \frac{ZN}{2})}{5}$$

The Y value is represented as follows:

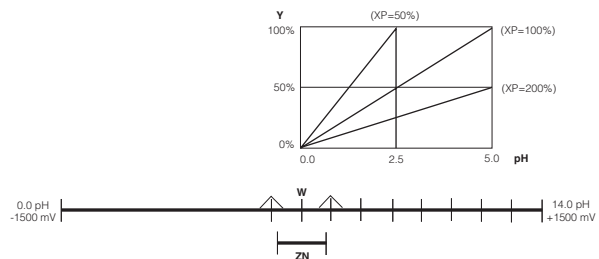

-Control by Frequency:

T length is programmed and the impulse time varies according to the sample pH.

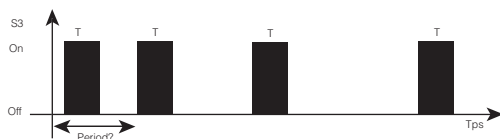

-Control by Impulse Length:

The periodicity (T) is programmed and the time period (∞) varies according to the sample pH.

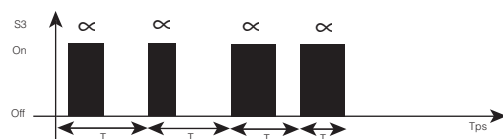



CONTROLLER		
CONTR.	-Yes -No	Option to use the controller
MODE	-Pul./Frq. -Frq./Pul. -PULSE -Frq.	Choose between controlling by impulse or by frequency or both
SETPOINT	XX.XX pH	Setpoint value
NEUT.Z	XX.X pH	Zone around setpoint where the regulation is not activated.
INTERIA	XXXs	Reaction time after activating relays S1 or S2: delay time after executing next period
REG.MAX.	XX	Maximum time out of the neutral zone before alarm is activated
S1/S2 MIN	XXX	Minimum closing time of relays S1, S2 to act upon commands. This parameter is used when the pH measurement is near the neutral zone.
S1 and S2 RELAYS		
COEEXP1/2	XXX%	Proportionality coefficient
T1/2	XXs	Control by impulse length ($3 < T < 60s$): corresponds to the impulse time period. Control by frequency ($0.1 < T < 0.7s$): Corresponds to impulse length.
MANUAL MODE		
S1/S2	Force relay S1 or S2. The user manually interfaces with the process. Pressing the function key activates the relay until the key is released. The icon is displayed according to the relay state.	

⇒ If the TIMER and CONTROLLER functions are active at the same time, the regulation is stopped during the timer cycle.

⇒ In controller mode, Relays S1 and S2 are normally open.

4.4.4 mA OUTPUTS Menu

The analog output signals allow the transmission of the measurements from the analyzer to any external control system.

It is highly recommended to use shielded cables for the output signals. This shielding should be connected to the earth terminal on the armor plate.

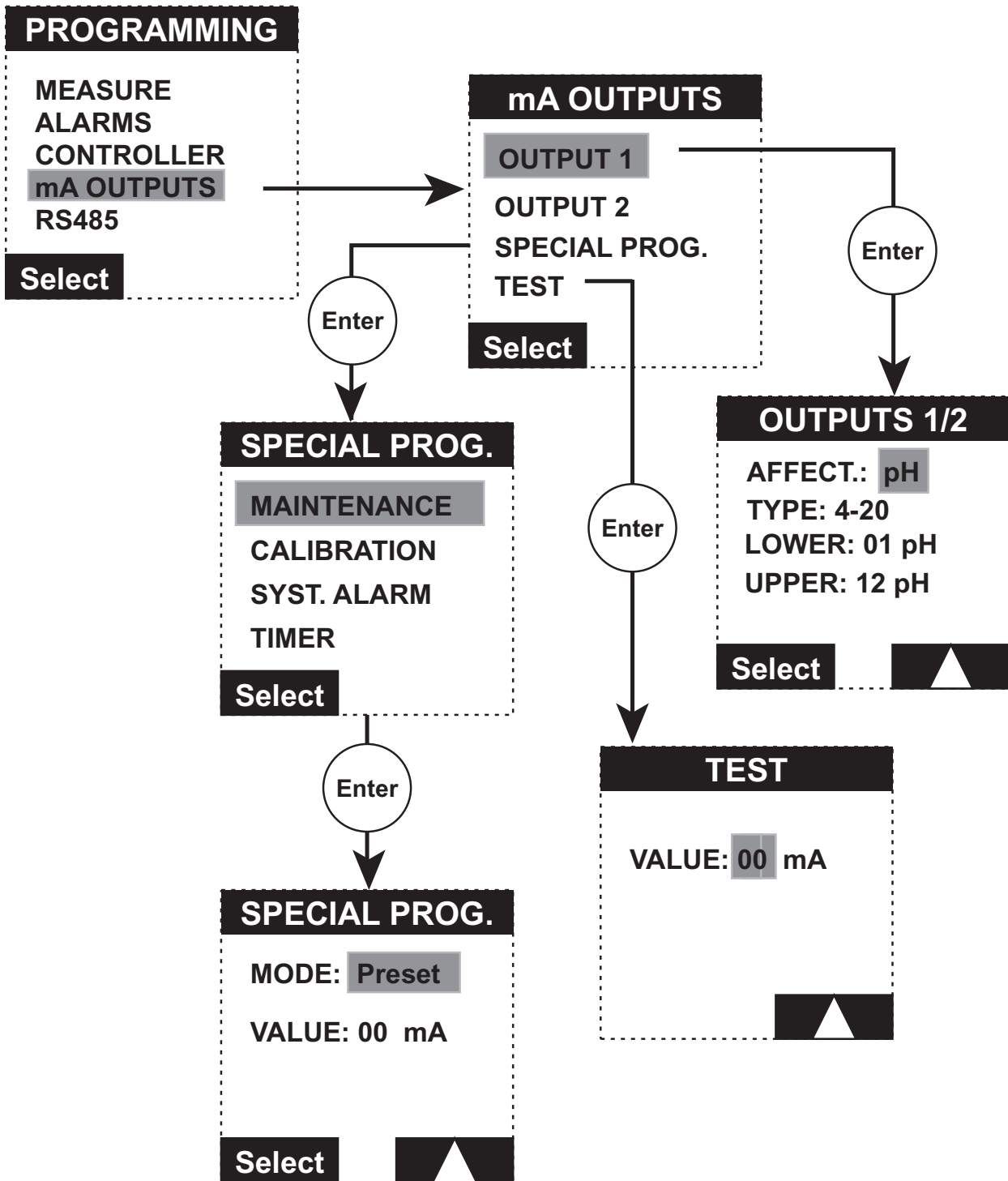



Output 1/2		
AFFECT	- pH - °C / °F	Choice of the analog output to measure pH or temperature
TYPE	0/20 4/20	Choice of the analog output type
LOWER	XXXX	Lower limit value
UPPER	XXXX	Upper limit value
Special Prog.		
MODE	- last - preset - live	Choice of the analog output during calibration, alarm, maintenance or timer cycles: Display and output will be last stored value, a preset value, or a live measurement
VALUE	XX	Preset value (0 to 21 mA)
Test		Test the analog outputs in 1 mA increments (0 to 21 mA)

4.4.5 RS485 Menu (Optional)

If the RS485 optional board is installed, program the parameters of the menu below. The optional RS485 board enables the connection between the analyzer and a digital communication system. The communication protocol is JBUS/MODBUS. Call Broadley Technologies for more information.

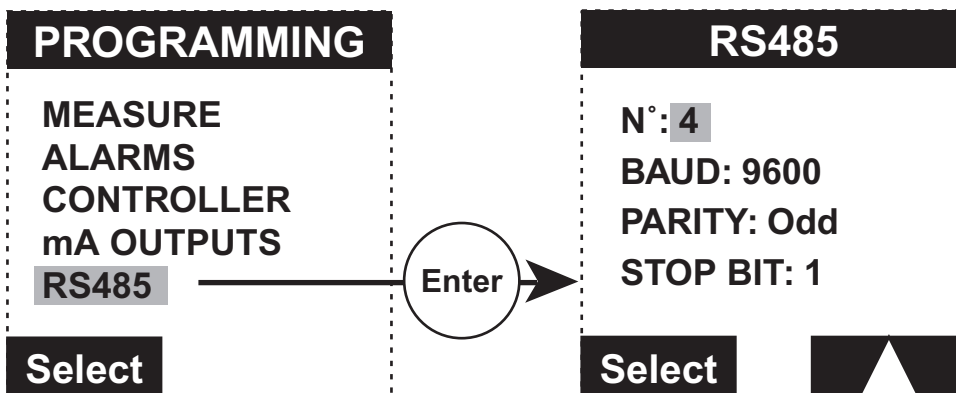



RS485		
N°	XX	MONEC number (0–32)
BAUD	- 300 - 600 - 1200 - 2400 - 4800 - 9600	Transmission speed in baud
PARITY	- No - Odd - Even	Without parity bit With odd parity bit With even parity bit
BIT STOP	- 1 - 2	1 bit stop 2 bit stop



4.5 SERVICE Menu



4.5.1 IMPEDANCES Menu

WARNING! An access code may be required. See page 4-19 for CODE Menu.

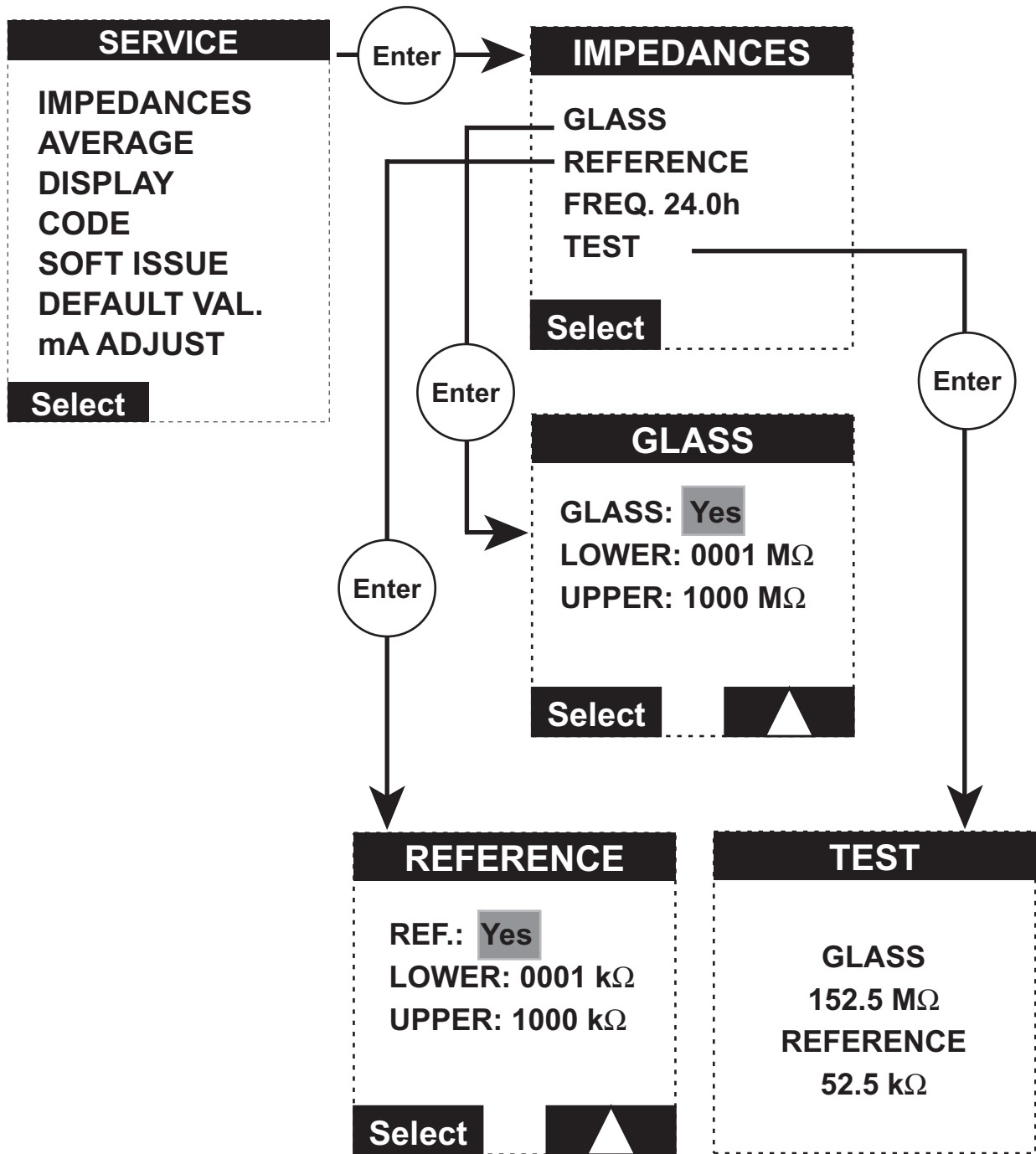



4.5.1 IMPEDENCES Menu (Continued)

The glass electrode impedance measurement is compensated to 25°C. This menu defines the lower and upper limits of the electrode impedances for the default detection, which should be defined experimentally.

IMPEDENCES		
Glass/Reference	-Yes -No	Allows and impedance measurement
FREQ.	XXXX h	Define the impedance measurement frequency (limits: 0.1 H to 24 H)
LOWER	XXXX mΩ	Defines the lower limit for the impedance measurement. This limit is used for the alarm system and the bargraph DISP 4.
UPPER	XXXX mΩ	Defines the upper limit for the impedance measurement. This limit is used for the alarm system and the bargraph DISP 4.
TEST	XXXX	View the impedance measurement value.

4.5.2 AVERAGE Menu

Program a moving average on the pH/redox measurement.

The measurement cycle lasts 2 seconds.



**An access code may be required.
See page 4-19 for CODE Menu.**

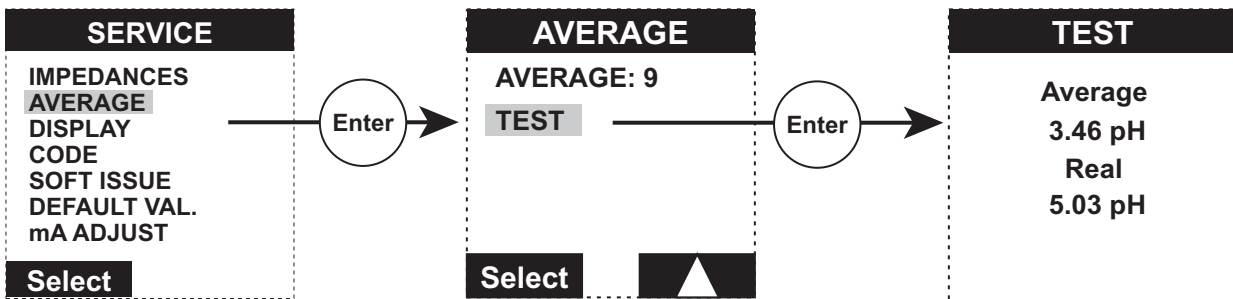

Average		
AVERAGE	X	Define the number of measurements to calculate the average
TEST		Display the difference between a measurement obtained with and without averaging

4.5.3 DISPLAY Menu

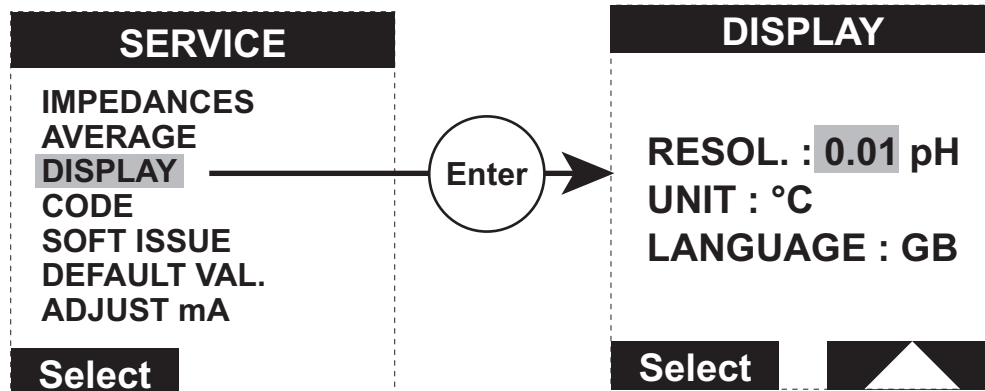

Display		
RESOL	- 0.01 pH - 0.1 pH	Choice of display resolution
TEMP.	- °C - °F	Choice of temperature units
LANGUAGE	- F - GB - D - Sp - I	Choice of languages : - French - English - German - Spanish - Italian



4.5.4 CODE Menu

Protection codes may be programmed for access to the PROGRAMMING, CALIBRATION, SERVICE menus. This code may be deactivated by entering 0000.

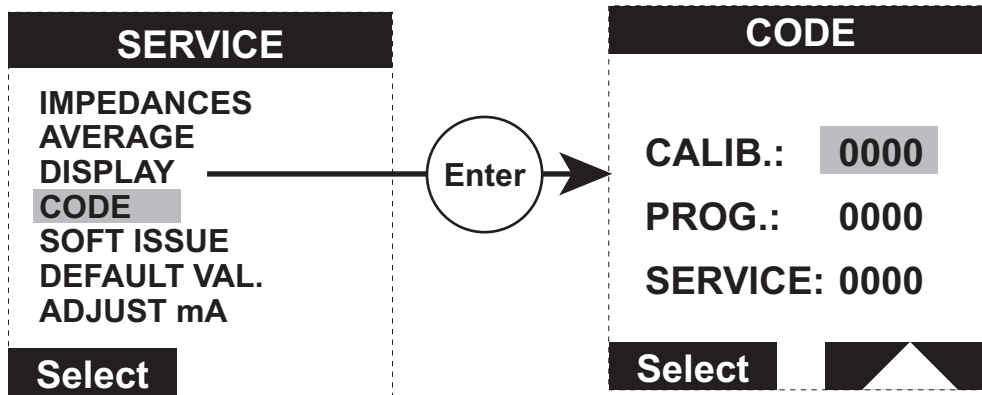

Code		
CALIB.	XXXX	Access code to the “CALIBRATION “ and temperature menus
PROG.	XXXX	Access code to the “PROGRAMMING” menu
SERVICE	XXXX	Access code to the “SERVICE” menu

To override the access code, press ESC and ENTER simultaneously to enter the menu selected.



4.5.5 SOFT ISSUE Menu

This menu displays the software version installed in the instrument.

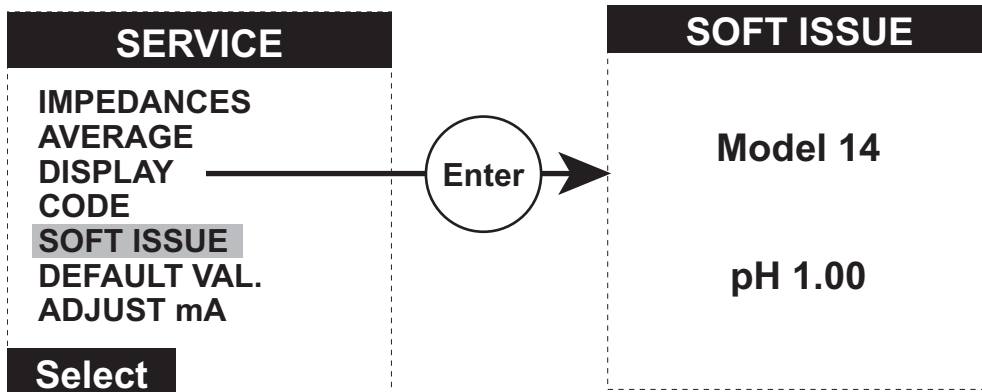

4.5.6 DEFAULT VALUES Menu

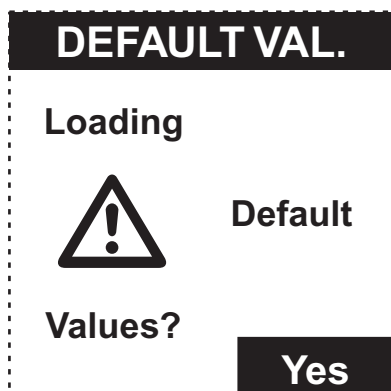

Pressing YES will load the default values. The current programmed values, historic values and calibration parameters will be lost.



4.5.7 ADJUST mA Menu

The analog output signals are factory-adjusted (upper limit: 20mA). However, if the upper limit of one of the outputs, drifts, the span value can be adjusted with the mA ADJUST menu. Connect an ampere meter in series to the analog output terminals. Adjust the value until the ampere meter displays 20mA.

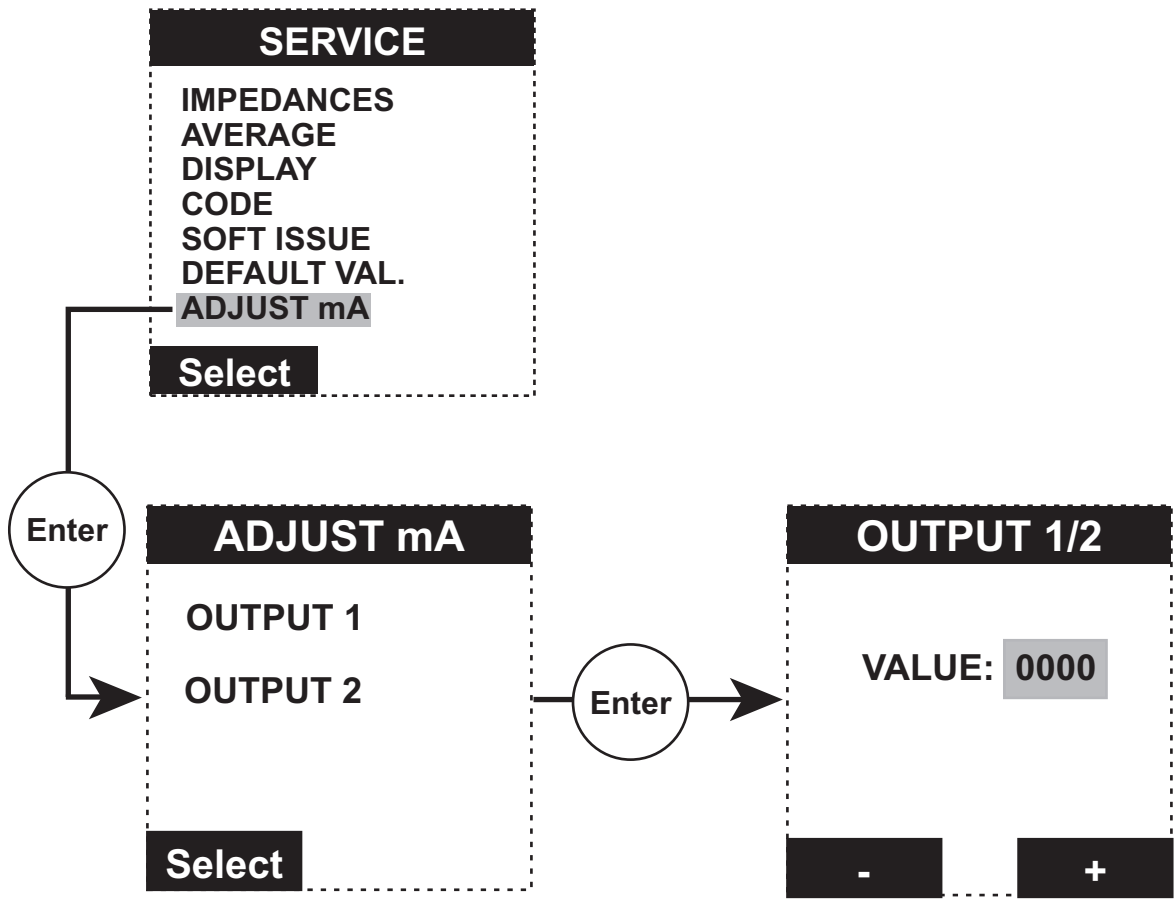





Chapter 5: Redox Programming



Warning ! An access code may be required in programming mode (See page 4-19).

Before programming a redox calibration, check the type of electrode to be programmed, select redox in the electrode menu. The Model 14 transmitter must first be configured for redox *before* calibration is begun.

5.1 Programming redox calibration

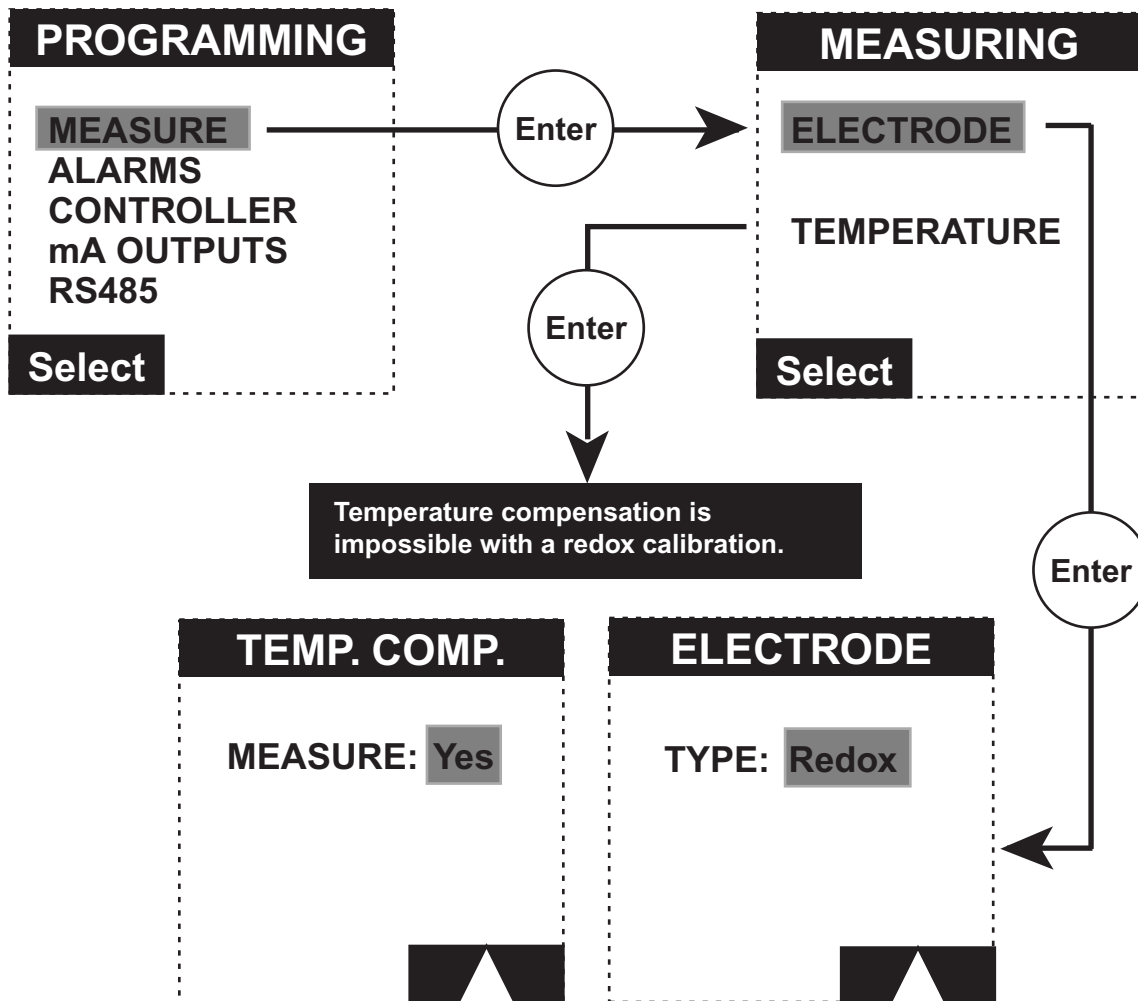

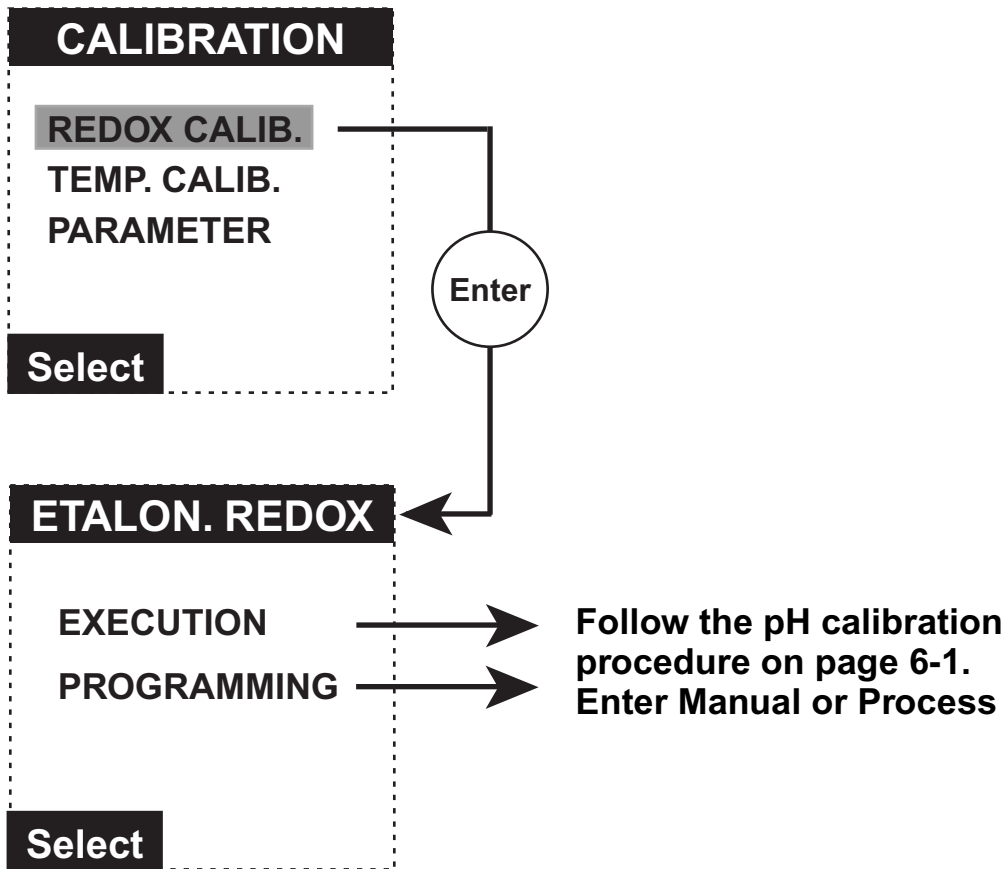

Note: The unit of measure for redox calibration is mV.

LIMITS:
-zero shift: ± 250 mV
-slope shift: 70 – 120%



Chapter 6: pH Calibration

6.1 Calibrating the Instrument

Confirm the parameters in the MEASURE Menu (page 4-5) are correctly configured before performing any calibration.



An access code may be required if it has been programmed.
(See page 4-19)

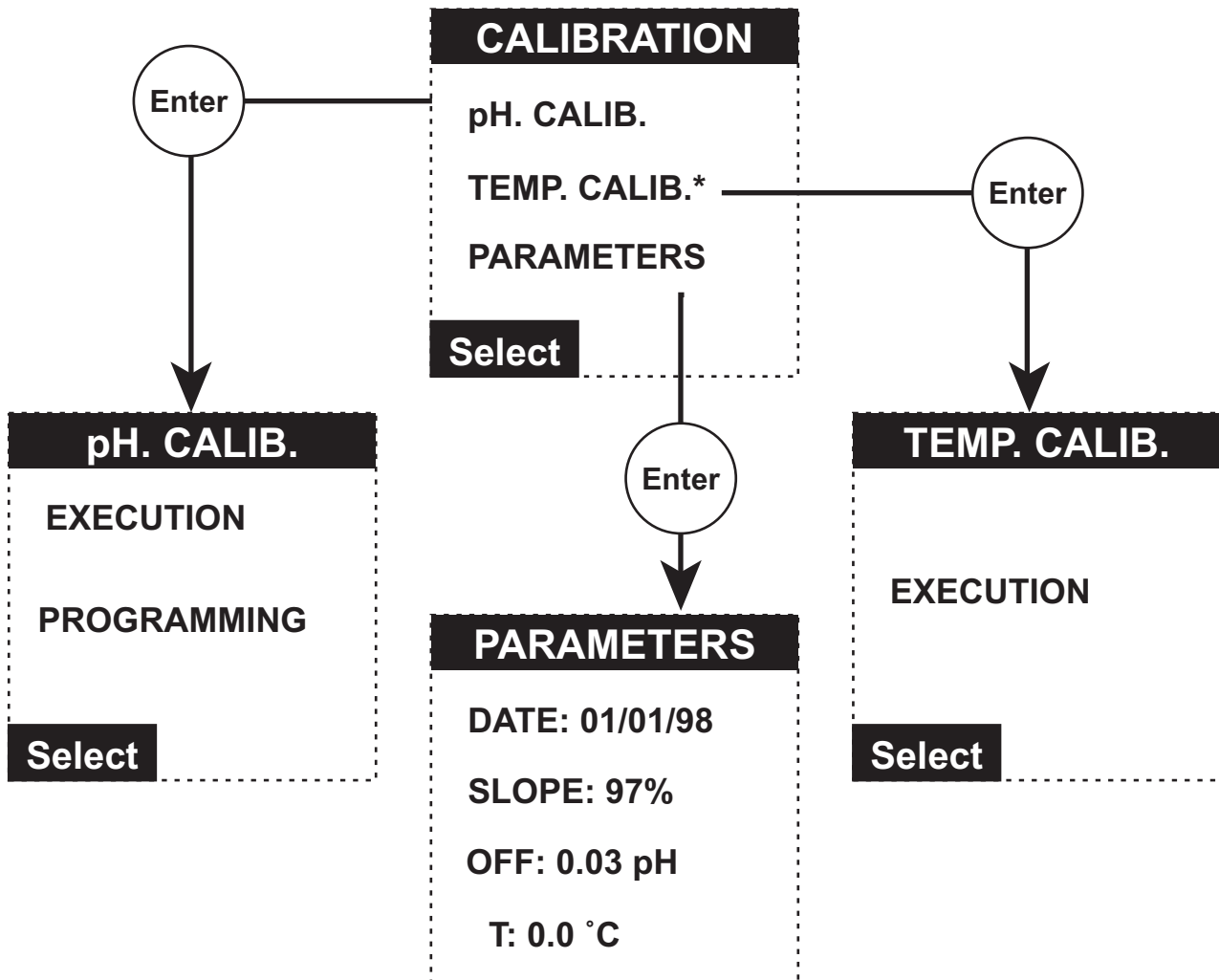

* This menu is displayed only if the Pt100/Pt1000 temperature measurement has been selected.

6.2 Temperature Calibration

The pH of a buffer solution depends upon the temperature. Consequently, nominal pH values are reference to 20°C. Refer to the buffer tables from the manufacturer to determine the pH of the solution at a specific tem-

perature. The temperature of the buffer solution needs to be entered only when operating in the manual mode.

The temperature element should be calibrated before performing any pH measurement.

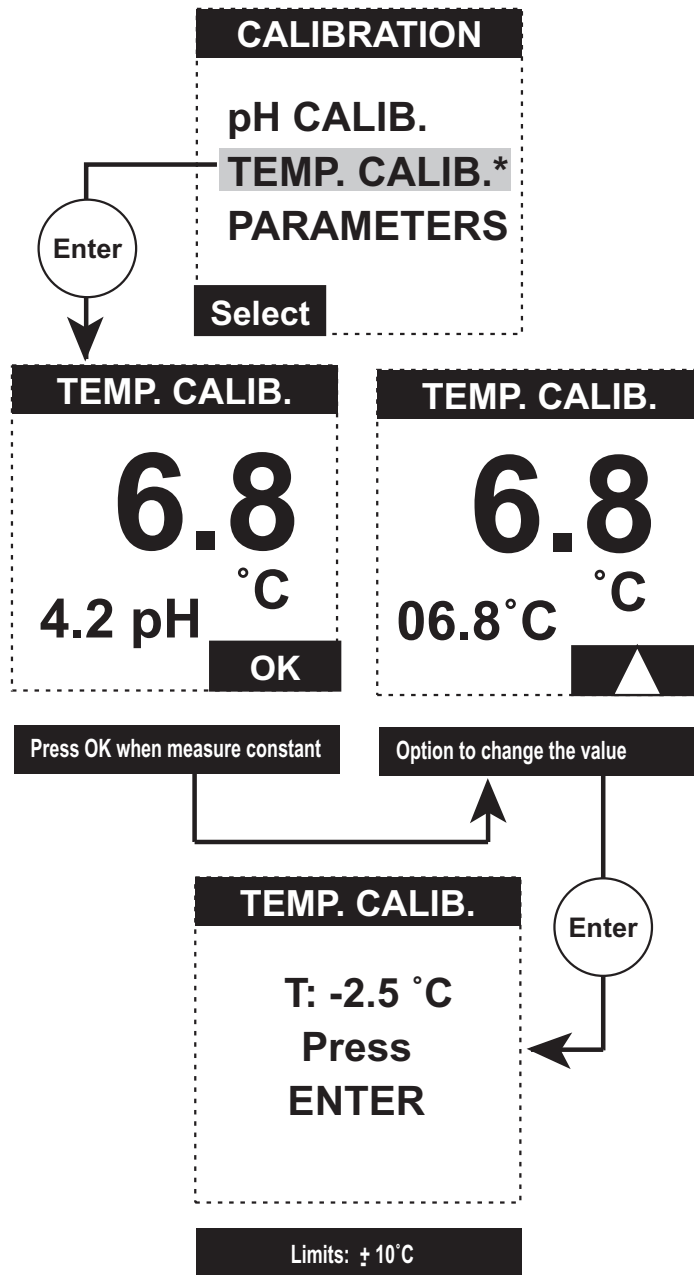

*The temperature calibration menu is only displayed when automatic temperature compensation (Pt100/Pt 1000) is selected.

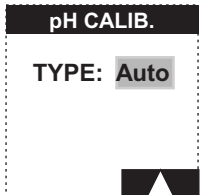
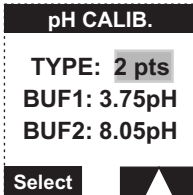
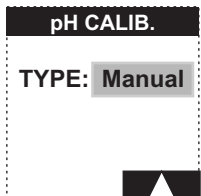
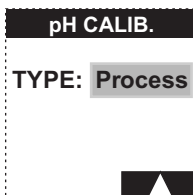
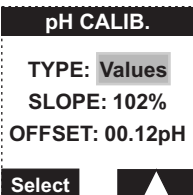

6.3 pH CALIBRATION Options

PROGRAMMING	UTILIZATION
<p>Automatic Calibration</p> 	<p>To be used ONLY when calibrating with 2 of the 3 standard buffers (4.00/6.88/9.22) programmed in the transmitter. The user does not have to enter a value when calibrating</p>
<p>2-Point Calibration</p> 	<p>To be used when calibrating with buffers other than 4.00, 6.88 or 9.22. The buffer value remains the same and the user enters them only one time when programming the calibration.</p>
<p>Manual Calibration</p> 	<p>To be used when calibrating with buffers other than 4.00, 6.88 and 9.22. The buffer value may change between 2 calibrations. The buffer values must be entered for each calibration.</p>
<p>Process Calibration</p> 	<p>Warning! This calibration is only active on the zero shift. The user calibrates on 1 point, using a buffer or the sample to the measure. The user needs to enter the buffer or sample value for each calibration.</p>
<p>Value Calibration</p> 	<p>If the electrode has been calibrated on another instrument, i.e. the laboratory, the slope and zero values of the electrode can be entered into the instrument.</p>



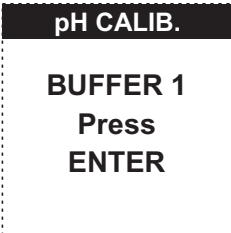
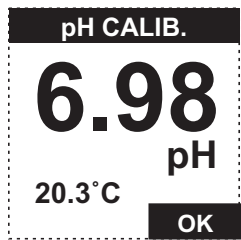
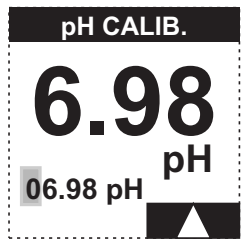
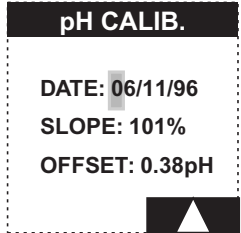

6.3.1 Two-Point Calibration

If automatic temperature compensation has been selected, immerse the ATC probe in the same calibration solution as the electrode.

	
	<p>Immerse the electrode in the first buffer.</p> <p>Press OK when the reading is stable. Press ESC to leave the menu without saving changes.</p> <p>Change the displayed value if necessary.</p>
	
<p>Repeat these steps for Buffer #2.</p>	
 <p>Limits: offset ± 3 pH slope 70 – 120 %</p>	<p>FOURTH STEP: Enter the date of the calibration if necessary. After the date, ENTER saves the calibration parameters; ESC does not save the changes and the former values remain.</p>

Chapter 7: Error Messages

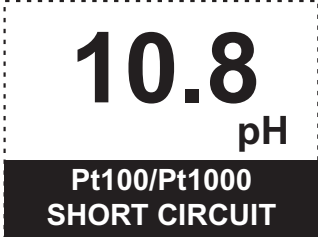
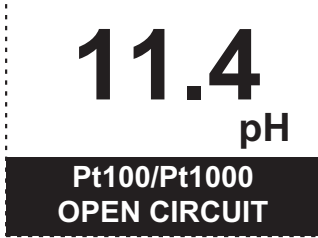
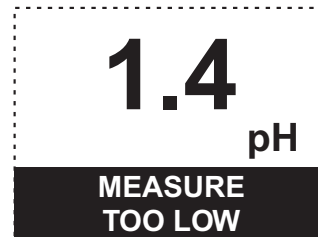
In manual mode, to suppress an error message press ENTER after correcting the default.

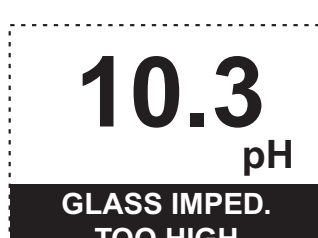
ERROR MESSAGES	DESCRIPTION
<div style="text-align: center;">  <p>10.8 pH Pt100/Pt1000 SHORT CIRCUIT</p> </div>	<p>Sensor is not connected correctly. Temperature sensor damaged, replace it if necessary.</p>
<div style="text-align: center;">  <p>11.4 pH Pt100/Pt1000 OPEN CIRCUIT</p> </div>	<p>Sensor is not connected correctly. Temperature sensor damaged, replace it if necessary.</p>
<div style="text-align: center;">  <p>1.4 pH MEASURE TOO LOW</p> </div>	<p>The pH value is below 3 pH.</p>
<div style="text-align: center;">  <p>13.4 pH MEASURE TOO HIGH</p> </div>	<p>The pH value is above 14 pH.</p>
<div style="text-align: center;">  <p>10.3 pH GLASS IMPED. TOO HIGH</p> </div>	<p>The glass electrode impedance is above the limits set by the user.</p> <ul style="list-style-type: none"> - change the limits - clean a coated electrode - replace the clogged electrode



ERROR MESSAGES	DESCRIPTION
<div style="border: 1px dashed black; padding: 10px; text-align: center;"> <p style="font-size: 2em; margin: 0;">7.9</p> <p style="margin: 0;">pH</p> <div style="background-color: black; color: white; padding: 5px; margin-top: 5px;"> <p style="margin: 0;">GLASS IMPED. TOO LOW</p> </div> </div>	<p>The glass electrode impedance is below the limits set by the user:</p> <ul style="list-style-type: none"> - change the limits - replace the electrode, it is probably broken
<div style="border: 1px dashed black; padding: 10px; text-align: center;"> <p style="font-size: 2em; margin: 0;">10.1</p> <p style="margin: 0;">pH</p> <div style="background-color: black; color: white; padding: 5px; margin-top: 5px;"> <p style="margin: 0;">REF. IMPED. TOO LOW</p> </div> </div>	<p>The reference electrode impedance is below the limits set by the user.</p> <ul style="list-style-type: none"> - change the limits - electrode is damaged, replace it.
<div style="border: 1px dashed black; padding: 10px; text-align: center;"> <p style="font-size: 2em; margin: 0;">6.4</p> <p style="margin: 0;">pH</p> <div style="background-color: black; color: white; padding: 5px; margin-top: 5px;"> <p style="margin: 0;">REF. IMPED. TOO HIGH</p> </div> </div>	<p>The reference electrode impedance is above the limits set by the user:</p> <ul style="list-style-type: none"> - change the limits - clean the electrode to remove particulates - replace electrode
<div style="border: 1px dashed black; padding: 10px; text-align: center;"> <p style="font-size: 2em; margin: 0;">5.8</p> <p style="margin: 0;">pH</p> <div style="background-color: black; color: white; padding: 5px; margin-top: 5px;"> <p style="margin: 0;">REGULATION TOO LONG</p> </div> </div>	<p>The time out of the neutral zone is above the limit programmed by the user:</p> <ul style="list-style-type: none"> - change the limits - check the relays S1 and S2



Error messages during a calibration Press ESC to leave the menu and calibrate again.	
<div style="border: 1px dashed black; padding: 5px; margin-bottom: 5px;"> <p>PH CALIB.</p> <p>SLOPE: 99.9%</p> <p>ZERO: 4.00 pH</p> </div> <div style="background-color: black; color: white; padding: 5px; margin-bottom: 5px;"> <p>REGULATION TOO LONG</p> </div>	<p>The zero shift is above the limit programmed.</p> <p>Limits :</p> <ul style="list-style-type: none"> - pH calibration : ±3 pH - redox calibration : ± 250 mV
<div style="border: 1px dashed black; padding: 5px; margin-bottom: 5px;"> <p>SLOPE: 130%</p> <p>ZERO: 0.1 pH</p> </div> <div style="background-color: black; color: white; padding: 5px; margin-bottom: 5px;"> <p>SLOPE OUT OF LIMITS</p> </div>	<p>The slope shift is above the limit programmed.</p> <p>Limits : 70–120 %</p>
<div style="border: 1px dashed black; padding: 5px; margin-bottom: 5px;"> <p>PH CALIB.</p> <p>ΔT:-20.0 °C</p> </div> <div style="background-color: black; color: white; padding: 5px; margin-bottom: 5px;"> <p>ΔT OUT OF LIMITS</p> </div>	<p>The temperature drift is above the limit programmed.</p> <p>Limits : -50°C to +20°C</p>
Error messages during an impedance measurement test Press ESC to leave the menu.	
<div style="border: 1px dashed black; padding: 5px; margin-bottom: 5px;"> <p>TEST</p> <p>GLASS</p> <p>TOO LOW</p> <p>REFERENCE</p> <p>TOO LOW</p> </div>	<p>The impedance measurement is below 5 MΩ for the glass electrode and 100 Ω for the reference electrode.</p>
<div style="border: 1px dashed black; padding: 5px; margin-bottom: 5px;"> <p>TEST</p> <p>GLASS</p> <p>TOO HIGH</p> <p>REFERENCE</p> <p>TOO HIGH</p> </div>	<p>The impedance measurement is above 1 GΩ for the glass electrode and 1 MΩ for the reference electrode.</p>



Chapter 8: Impedance Measurement

8.1. Electrode Impedance: Electrode Integrity Index

A method generally used to detect an electrode default is to calibrate a pH measurement system in buffer solution. If the slope or the zero (asymmetry) characteristics are out of the programmed limits, one of the electrodes is considered to be damaged.

Another method consists of the manual measurement of both electrode impedances. This method is easy to perform with the reference electrode, but intricate with the glass electrode which has a high impedance.

For both methods the electrodes need to be withdrawn from the process.

Electrode defaults are usually caused by:

1. A crack in the glass membrane which shows a low **impedance** between the sample and the electrode
2. A contaminated electrode (deposit) which shows a weaker measurement sensibility and an electrode **high impedance**
3. A lack of electrolyte in the reference electrode which shows a **very high impedance**

4. A contaminated reference electrode by chlorides or sulfides, which precipitate with silver ions and may clog the electrolytic junction. This contamination shows a **high increase in the impedance**.

In the Model 14 transmitter, the electrode impedance measurement results from the measurement system without addition of commutation circuits.

8.2 Measurement Principle

A non-oxidizing electrode permits setting the liquid potential to the zero measured. A very stable voltage (equal to E) is applied to the electrode. The two capacities are loaded through the electrode impedance. After a certain time (which depends on the impedance measured), the system measures the potential variation on each electrode.

The process temperature is measured to compensate the impedance measurement of the glass electrode.

The measured impedance drift of the glass electrode, according to the temperature is represented by the curve below:

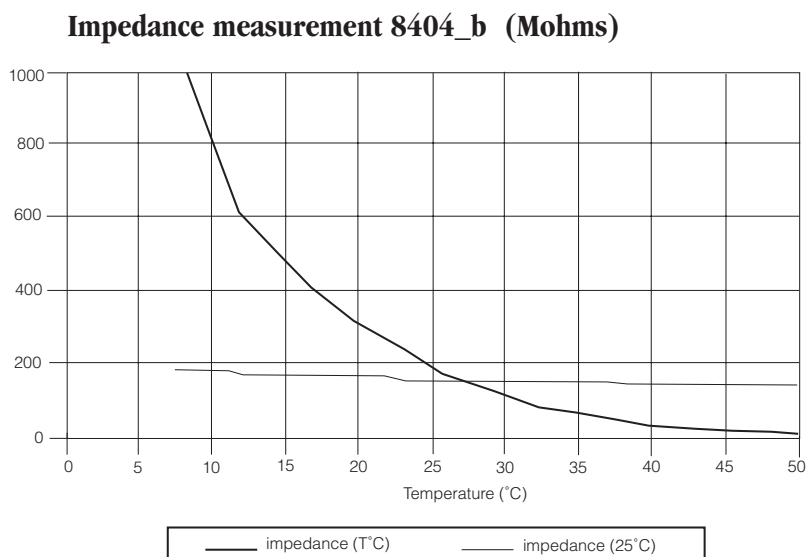





Appendix 1: Technical Specifications

Operating Conditions

Ambient Temperature	-20°C to +60°C
Relative Humidity	0 – 90%

Measure

Display Range	0 – 14 pH (Can measure down to -3 pH) -1500 mV – 1500 mV -20°C to 200°C (- 4°F – 392°F)
Display Resolution	0.01 pH / 0.1 pH (adjustable) 1 mV 0.1°C
Repeatability	±0.02 pH ±1 mV ±0.2°C
Temperature Sensor	Pt 100 / Pt 1000
Automatic Temperature Compensation Range	-20 to 200°C -4 to 395°F
Temperature Compensation Range	Nernst Ultrapure water Other tables
Electrode Type	- glass (with or without preamplifier) - antimony - redox - programmable (slope + Uiso + pHiso)
Cable Length	0 to 25 m (high impedance) 0 to 100 m (low impedance)
Sensor Inputs	Differential Measurement
Input Impedance	> 10 ¹² Ω
Impedance Measurement	Glass: 5M Ω – 1 GΩ Reference: 100 Ω – 1M Ω

Calibration

Calibration Type	- 2 points (automatic) - 2 points (manual) - 1 point process
Slope Matching	41 to 71 mV @ 25°C 70–120 %
Zero Matching	±3 pH ±250 mV
Temperature Calibration	- 50°C to +20°C (- 90°F to +36°F)

Controller

Setpoint	Programmable in the range 0–14 pH or -1500 mV to +1500 mV
Neutral Zone	Programmable from 0–3 pH or 0–200 mV symmetric around the Regulating point
Proportional Band	Programmable from 0 to 500%
Periodicity	Programmable from 3 to 60 seconds (impulse control) or from 1 to 30 seconds (frequency control)
Controller Output	2 isolated contacts S1 and S2 S1 : base injection S2 : acid injection
Automatic/Manual Switch	Possible

Analog Output

Output Signals	2 isolated galvanic outputs
Allocation	pH / redox / temperature
Type	0 to 20 mA 4 to 20 mA
Maximum Load	800 Ω
Accuracy	0.1 mA



Alarms

Number of Alarms	4
Function	Limits Alarm System Timer
Hysteresis	0 to 10%
Temporization	0 to 999 s
Breaking Power (ohm overcharge)	250 V AC, 5A max 100 V DC, 0.7A max
Response Time	10 ms
Relaxation Time	5 ms

RS485

Baud Rate	300 ... 9600 bauds
Insulation	Galvanic
Station Number	32 max

Programming

Language	French English German Italian Spanish Dutch
Display	Icons and graphic zone (80 x 64 pixels)
Protection Codes	Calibration Programming Service

Alarms

Power Supply Voltage	1. standard version : - 90 V – 265 V AC 50/60 Hz
Preamplifier	± 9 V DC
Connections	2.5 mm ² screw terminals
Consumption	25 VA
European Standards	EN 50081 & EN 50082 EN 61010-1



Mechanical Characteristics

Dimensions	144 mm x 144 mm x 150 mm (5.7" x 5.7" x 6")
Weight	2 kg
Material	Housing : Epoxy coated aluminum Screws : Stainless steel
Specification	IP66
Mounting Types	Wall Pipe Panel
Cable Glands	2 x Pg13 2 x Pg11



Appendix 2: Default Values

Calibration

pH CALIB.
TYPE : Auto

PARAMETERS
DATE :01/01/96
SLOPE :100.0%
OFFSET : 0.00 pH
°T : 0.0 °C

Programming

MEASURE

ELECTRODE
TYPE : Glass

TEMP. COMP.
MEASURE : No
TEMP. : 25 °C
COMP. : Nernst

ALARMS

ALARMS S1/S2/S3/S4

AFFECT. : pH
LIMIT : 0.00 pH
DIR. : Down
DELAY : 000 s
HYST. : 00%
RELAY : NO

mA OUTPUTS

OUTPUT 1
AFFECT. : pH
TYPE : 0-20
LOWER : 00.00 pH
UPPER : 14.00 pH

OUTPUT 2
AFFECT. : pH
TYPE : 0-20
LOWER : 00.00 pH
UPPER: 14.00 pH

SPECIAL PROG.

MAINTENANCE
MODE : Preset
VALUE : 0.00 mA

CALIBRATION
MODE : Live

SYST. ALARM
MODE : Live



RS485

No : 0
BAUD : 9600
PARITY : Non
BIT STOP : 1

Service

IMPEDANCES

FREQUENCY : 24.0 H

GLASS

GLASS : No

REFERENCE

REFERENCE : No

AVERAGE

AVERAGE : 0

DISPLAY

DISPLAY

RES. : 0.01 pH

UNIT : °C

LANGUAGE : GB

CODE

CALIB. : 0000

PROG. : 0000

SERVICE : 0000



Appendix 3: Temperature Conversion Chart

- Conversion from °C into °F : $^{\circ}\text{F} = 1.8 \times ^{\circ}\text{C} + 32$
- Conversion from °C into °K : $^{\circ}\text{K} = ^{\circ}\text{C} + 273.15$

°C	°F	°K
0	32	273.15
1	33.8	274.15
2	35.6	275.15
3	37.4	276.15
4	39.2	277.15
5	41	278.15
6	42.8	279.15
7	44.6	280.15
8	46.4	281.15
9	48.2	282.15
10	50	283.15
11	51.8	284.15
12	53.6	285.15
13	55.4	286.15
14	57.2	287.15
15	59	288.15
16	60.8	289.15
17	62.6	290.15
18	64.4	291.15
19	66.2	292.15
20	68	293.15
21	69.8	294.15
22	71.6	295.15

°C	°F	°K
23	73.4	296.15
24	75.2	297.15
25	77	298.15
26	78.8	299.15
27	80.6	300.15
28	82.4	301.15
29	84.2	302.15
30	86	303.15
31	87.8	304.15
32	89.6	305.15
33	91.4	306.15
34	93.2	307.15
35	95	308.15
36	96.8	309.15
37	98.6	310.15
38	100.4	311.15
39	102.2	312.15
40	104	313.15
41	105.8	314.15
42	107.6	315.15
43	109.4	316.15
44	111.2	317.15
45	113	318.15