

Broadley-James®

**Dissolved Oxygen Sensor  
Membrane Storage Vial  
Exploded Views**

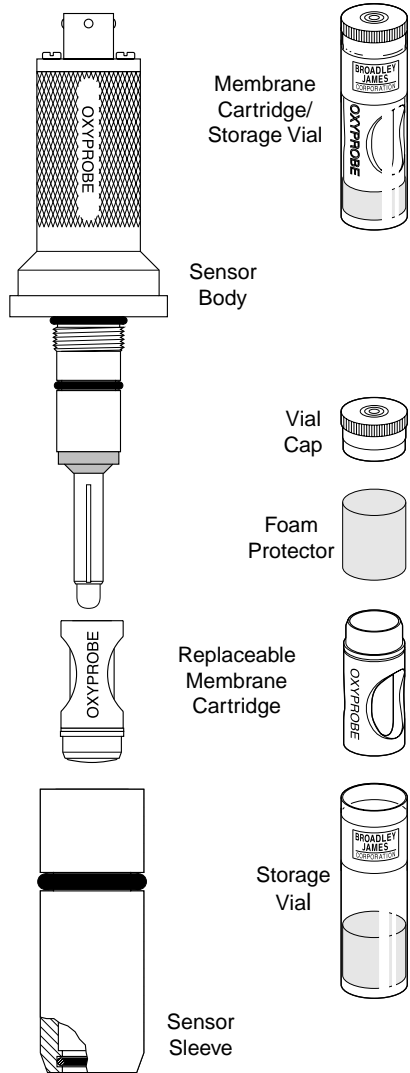

19 THOMAS • IRVINE, CA 92618 • USA

**Manufacturers of pH and D.O. Sensors  
for Science and Industry**

**ORDER DESK & TECHNICAL SERVICE**  
Telephone:  
1-888 DO PROBE (367-7623)  
(949) 829-5555

FAX:  
(949) 829-5560

**Broadley-James®  
OxyProbe®  
Membrane Tester**

**TESTER INFORMATION**

Part Number: AM-9425  
Membrane Size: 19 mm & 25 mm  
D.O. Sensors  
Syringe Size: 10 cc  
Syringe Tip: Luer Lock

OxyProbe® is a registered trademark of  
Broadley-James Corporation, Irvine,  
CA 92618 USA

Broadley-James®

**FIGURE 1.  
VISUAL EXAMINATION**

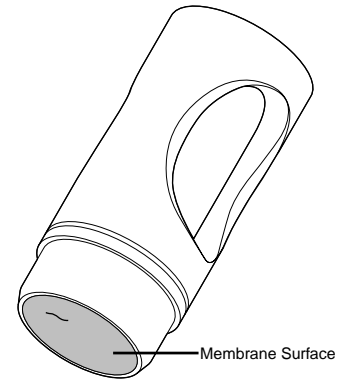

**Step 1.**  
Inspect the outer surface of the polymer  
membrane for any visible scratch, scar, or  
abrasion.

**FIGURE 2.  
PLUNGER "READY" POSITION**

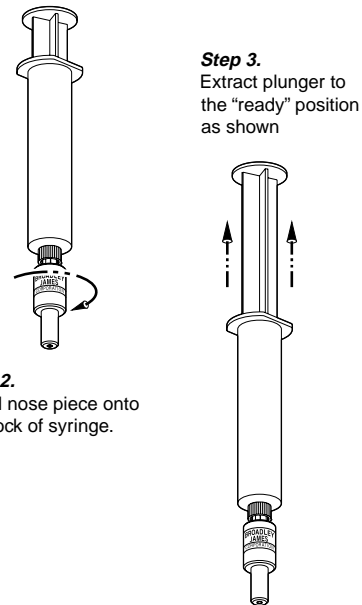

**Step 2.**  
Install nose piece onto  
luer lock of syringe.

**Step 3.**  
Extract plunger to  
the "ready" position  
as shown

**FIGURE 3.  
MEMBRANE CARTRIDGE  
INSTALLATION**

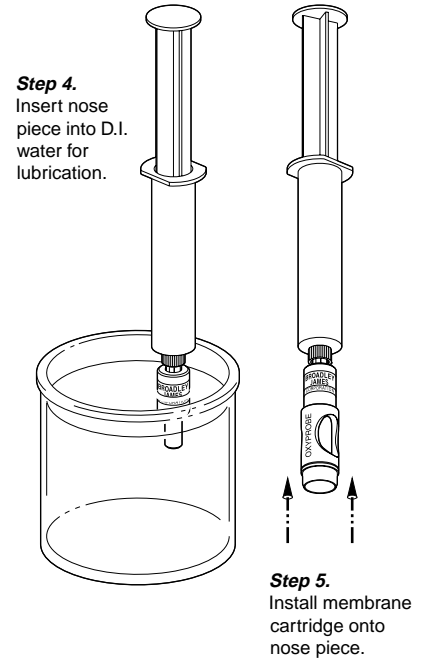

**Step 4.**  
Insert nose  
piece into D.I.  
water for  
lubrication.

**Step 5.**  
Install membrane  
cartridge onto  
nose piece.

**FIGURE 4.  
APPLYING PRESSURE TO  
MEMBRANE CARTRIDGE**

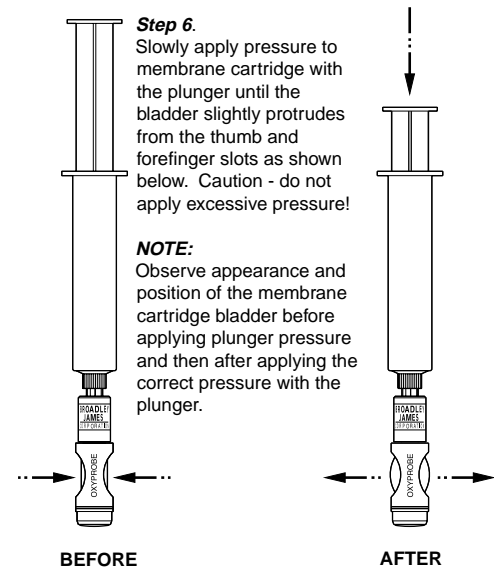

**Step 6.**  
Slowly apply pressure to  
membrane cartridge with  
the plunger until the  
bladder slightly protrudes  
from the thumb and  
forefinger slots as shown  
below. Caution - do not  
apply excessive pressure!

**NOTE:**  
Observe appearance and  
position of the membrane  
cartridge bladder before  
applying plunger pressure  
and then after applying the  
correct pressure with the  
plunger.

BEFORE

AFTER

**FIGURE 5.  
MEMBRANE CARTRIDGE TEST**

**Step 7.**  
Follow the simple  
procedures shown  
below:

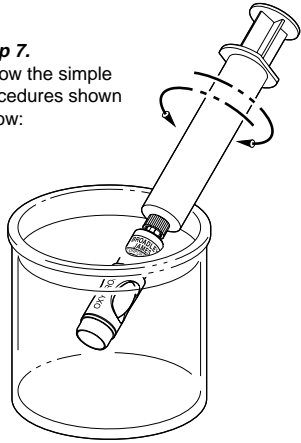

**PRESSURE TEST PROCEDURES:**

1. Insert membrane tester with membrane cartridge into a beaker of D.I. water. Make certain that the front of the membrane cartridge is completely submerged.
2. While maintaining a slight pressure on the plunger to keep the bladder extended as shown in Fig. 4, slowly rotate the test assembly in the water.
3. Look for any signs of air bubbles which indicate a damaged membrane or bladder. Refer to Fig. 6 for typical examples of air leaks found when the membrane has been damaged.

**NOTE:**

- A good membrane will not permit any air to escape from the membrane cartridge when this test is properly applied.

**FIGURE 6.  
DAMAGED MEMBRANE CARTRIDGES**

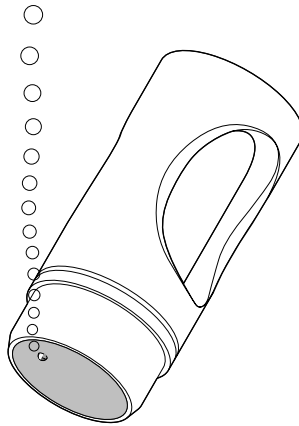

**Example 1:**  
Rapid leak, visible air bubbles escaping through polymer membrane.

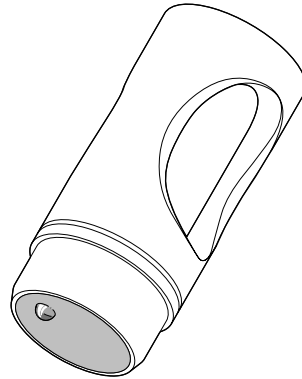

**Example 2:**  
Slow leak, air bubble(s) attached to surface of polymer membrane, and reappear when wiped off.

**SUMMARY:**

1. Remove the membrane cartridge from its storage vial or from the dissolved oxygen sensor. Be careful not to scratch or abrade the polymer membrane portion of the cartridge.
2. Visually inspect the polymer membrane outer surface area for any scratches, scars, abrasions or tears. See Fig. 1.
3. Install the nose piece onto the syringe and extract the plunger of the membrane tester to the "ready" position as shown in Fig. 2.
4. Insert the tip of the membrane tester into D.I. water to lubricate it before installing the membrane cartridge as shown in Fig. 3. Avoid excessive force.
5. Slowly compress the plunger until the membrane cartridge bladder slightly protrudes from the thumb and forefinger slots of the cartridge housing as shown in Fig. 4.
6. Place membrane tester with the membrane cartridge into a beaker of D.I. water as shown in Fig. 5. Observe for the presence of air bubbles representing either a rapid leak or slow leak as shown in Fig. 6.

**NOTES:**

- A good membrane cartridge will not have any signs of air bubble generation during this test.
- Replace a cartridge with any signs of air leakage, whether flowing from or clinging to the surface of the polymer membrane.
- New membrane cartridges should always be kept in their individual storage vials until required for service. Avoid unnecessary handling.
- A used membrane cartridge installed on a dissolved oxygen sensor should be protected during nonuse.

**PURPOSE FOR TEST:**

1. D.O. sensor membrane cartridges contain a Oxygen permeable polymer membrane which is liquid impermeable.
2. Improper storage or accidental handling of the D.O. sensor or its membrane cartridge can damage the polymer membrane.
3. A hairline scratch, slight abrasion, or tear of any type of the polymer membrane, even though not visible to the naked eye, may render the membrane cartridge inoperable.
4. Prior to use, a membrane cartridge should be tested for its liquid tight integrity.