



19 THOMAS • IRVINE, CA 92618 • USA

Manufacturers of pH & DO Sensors
for Science and Industry

ORDER DESK & TECHNICAL SERVICE

Telephone:
1-800-288-2833
(949) 829-5555

FAX:
(949) 829-5560

Broadley-James® Fermprobe® ORP Electrodes

Designed with
**Sealed Ag/AgCl
and Dual Salt Bridge**
REFERENCE HALF-CELL

For use in all steam sterilizable and autoclavable ORP (Redox) measurement applications. T-Pull handle and/or integral cable styles are not autoclavable.

ELECTRODE SPECIFICATIONS

ORP Range:	± 5000 mV
Sensing Tip:	Platinum Band, 99.99% pure, 0.25" O.D. x 0.1" L
Temperature Range:	-5 - 135°C
Pressure:	150 psig max.
Cable:	Low Noise Coax, dual shielded

PREPARATION FOR USE:

1. Remove electrode from the "soaker bottle" containing the storage solution (3.8 Molar KCl) by unscrewing the bottle from the lid/electrode. Carefully slip the lid and sealing O ring off the electrode body.
2. Save the electrode's "soaker bottle", cap, and sealing O ring for future use as a storage container for the Fermprobe when it is not in service. Be certain to use 3.8M KCl (BJC P/N: AS-3120-C20-0500) as the storage solution.

NOTE:

- DO NOT remove the teflon spacer and O ring which are fitted to the electrode body just beneath the electrode's cap.
3. For first-time use after removing the ORP Fermprobe from its storage solution: Inspect the electrode for any signs of breakage or shipping damage and commence with its use in your application.
 4. For reuse of the Fermprobe, or after long term storage in a solution other than the recommended 3.8M KCl solution: Immerse the lower 30mm of the Fermprobe in a 3.8M KCl solution for 10 to 30 minutes. This prepares the ceramic liquid junction for contact with solutions to be tested.

TESTING PROCEDURE:

1. Unlike pH electrodes, redox electrode measurement half-cells undergo no changes of zero-point nor of slope. Nevertheless, incorrect redox potentials may be occasionally measured and the cause of these errors is usually a contaminated Pt surface. In such cases, the electrode may be regenerated by cleaning as described in the next section. To test the Redox Fermprobe's accuracy proceed with the following Quinhydrone tests.

CAUTION:

Quinhydrone is very toxic and should be handled by qualified technicians only. Handle with care and avoid ingesting. Avoid contact with bare skin. Dispose of the Quinhydrone solutions per your local waste water regulations.

2. The oxidation-reduction potential of a Quinhydrone solution is pH dependent. By saturating pH buffers with Quinhydrone you can make stable mV standard solutions to use in testing your Redox Fermprobe®. Ideal values for some common buffers (saturated with Quinhydrone) are listed below:

7.00 pH +86 mV

4.01 pH +263 mV

Δ = 2.99 pH Δ = 177 mV

3. Electrode construction and prior usage will make the actual magnitude of the first two test readings vary. The actual readings in the buffers could vary by ± 20 mV.

However, a clean Redox Fermprobe will give reproducible Δ values of Δ173 ± 4mV. It is this Δ value that provides an indication of the functional performance of the electrode.

Procedure:

- a. Place 50 -100 ml of pH 7.00 and 4.01 buffers in suitably sized beakers, stir about 0.2g/100ml of Quinhydrone into each buffer.

NOTE:

- The Quinhydrone will not all dissolve. The intention here is to prepare a saturated solution. There should be a little of the powder undissolved.
- b. Prepare the Redox Fermprobe for testing by cleaning the platinum sur-

face with liquid soap and soft toothbrush (do not scar or scratch the platinum surface). Consult factory prior to use of solvents or other cleaning agents. Rinse thoroughly with clean tap water.

- c. Connect the Redox Fermprobe to a suitable pH Meter, set to the milli-volt scale.
- d. Immerse the electrode in the pH 7.00-Quinhydrone mixture. The meter should read between +70 and +110 millivolts.
- e. Rinse the electrode thoroughly with clean tap water, and immerse it in the pH 4.01-Quinhydrone mixture. The meter should now read between +240 and +280 millivolts.

NOTES:

- This test verifies the function of the platinum combination Redox(ORP) electrode by actual measurement of a known oxidation-reduction potential change. If an electrode responds adequately in this test (e.g. Δ169 to Δ177 mV between the 7 and 4 buffer-Quinhydrone mixtures) but the values fall outside of these ranges, it indicates a plugged reference junction or a contaminated reference internal solution.
- The buffer-Quinhydrone mixtures will not remain useful for more than two hours since the Quinhydrone decomposes slowly in contact with air. Dispose of this solution per local waste water regulations.

CLEANING A FERMPROBE® WITH IMPAIRED RESPONSE:

Used electrodes which are physically intact, can sometimes be restored to an improved level of performance. All electrodes have a given useful life span depending

on the conditions of use. One of the following procedures may prove helpful in restoring a used electrode.

1. **Initial Cleaning:** Wash with a solution of liquid detergent or enzyme detergent and warm water by gently scrubbing with a soft toothbrush or soft tissue. Follow with thorough rinse in D.I. or clean tap water.
2. **Inorganic Scale Deposits:** Dissolve deposit by immersion of the electrode's Pt measurement tip in **dilute** hydrochloric acid for a few minutes followed by a thorough rinse with D.I. or clean tap water. Platinum bands can be polished with a fine grade of alumina (Al₂O₃) or some similarly fine polishing compound.
3. **Organic Oil or Grease Films:** If film is known to be soluble in a particular organic solvent which is not harmful to platinum or glass, wash it with this solvent. Repeat step #1 above. Depending on the extent of the oil and/or grease contamination, it should be noted that the reference half-cell's ceramic liquid junction may be damaged beyond recovery.
4. **Plugged or Dry Ceramic Liquid Junction:** Remove contaminant with one of the above procedures, then soak in 2M KCl solution for 30 - 45 minutes.

NOTES:

- Do not permit electrode to dehydrate or dry out. Always keep in a wetted environment especially when not in service.
- Cracked or broken electrodes are not repairable.
- Inspect cable and connector to ensure that the insulation integrity is intact and that there are no signs of corrosion or contaminants on the metal components.

STORAGE:

1. Short Term: Immerse electrode measurement tip and liquid junction surface areas in 3.8M KCl. If this solution is not available, use 4.01 pH buffer, clean tap water, or lastly, a sample of the process being measured to keep the electrode hydrated.
2. Long Term: Fill soaker bottle that the electrode was originally shipped in with a freshly prepared 3.8M KCl solution and insert electrode. Be certain that the soaker bottle's sealing O-ring and cap are securely in place. Tighten cap hand tight only. The electrode should be stored in an upright (vertical) position.

OXIDATION-REDUCTION POTENTIAL MEASUREMENTS WITH A REDOX FERMPROBE®

The Redox Fermprobe electrodes are designed for the measurement of the Oxidation-Reduction Potential of a fermentation broth or other aqueous medium. The electrode is used in conjunction with a pH meter or other electroanalytical instrumentation that can be set to read millivolts.

The Redox Fermprobe is a combination electrode with a reference electrode and Platinum band electrode built into one electrode body. Essentially the measured redox potential is the EMF difference between the potential on the Platinum band and the potential of the built-in reference electrode.

The potential measured with the Redox Fermprobe is proportional to the ratio of the concentration of the oxidized and reduced states of the elements and compounds that make up the test sample. The potential of the Redox Fermprobe can be expressed by the general form of the Nernst equation:

Equation 1.

$$E = E_O + \frac{E_N}{N} \log \frac{[\text{Oxidant}]}{[\text{Reductant}]} @ 25^\circ\text{C}$$

Where:

E = the voltage potential observed with the Redox Fermprobe

E_O = A constant characteristic of the system in question (mV)

E_N = Nernst potential (59.2 mV @ 25° C)

N = the number of electrons reacting in the redox equation.

Some work requires that the measured potential E be converted to E_h. The value E_h is the observed potential difference between the Platinum band and a normal Hydrogen electrode as the reference; (the potential of which is zero by definition). Since the normal Hydrogen electrode is rarely used as a reference in actual measurements, the measured potential E will not be equal to E_h.

However, E_h can be calculated by adding algebraically the measured potential E and the standard potential, E_R, of the reference electrode that is actually used for the sample measurement. The standard potential E_R is the difference between the measuring reference electrode and the normal Hydrogen electrode at 25° C. Therefore:

Equation 2.

$$E_h = E + E_R$$

Where:

E_R = standard potential of the reference electrode.

Please note that the reference electrodes used in the Fermprobe series of combination electrodes are the Ag-AgCl type utilizing a 3.8 M KCl electrolyte salt bridge. The standard potential E_R of the Fermprobe series reference is + 202 mV at 25° C (see Table 1 for other temperatures).

Example:
If the potential E is measured with the Redox Fermprobe and is found to be 400 mV at 25° C, then the E_h (at 25° C of the test sample is calculated as follows:

$$E_h = E + E_R$$

$$E_h = 400 \text{ mV} + 202 \text{ mV}$$

$$E_h = 602 \text{ mV}$$

Please note that the values E and E_h, and E_R, are all temperature dependent.

Use Table 1 for values of E_R at temperatures other than 25° C. These values are necessary to calculate E_h at temperatures other than 25° C with Equation 2.

TABLE 1
E_R Values for the Redox Fermprobe

Temp.(°C)	E _R (mV)
15°	209
20°	206
25°	202
30°	198
35°	195
38°	193
40°	191

TABLE 2
Nernst Potentials (E_N) from 15° to 40° C

Temp.(°C)	E _N (mV)
15°	57.2
20°	58.2
25°	59.2
30°	60.1
35°	61.1
38°	61.7
40°	62.1

The actual magnitude of the potentials E or E_h of any particular Oxidation-Reduction system will depend on three things:

- (1) The constants of that system, E_O and N
- (2) The temperature dependent values, E_N and E_R (see tables 1 and 2)
- (3) The ratio of concentrations of the oxidants and reductants in the system

Therefore, in any reversible Oxidation-Reduction system the measured potential E and the calculated potential E_h are both functions of the temperature and of the ratio of concentrations of the oxidants and the reductants. Please note that if all measurements are done at the same temperature

(in a temperature controlled fermentation tank for example) then the temperature dependent values become constants.

Regardless of the initial magnitude of the values E and E_h, both values will become more positive when the concentration of the oxidant increases relative to the reductant (oxidizing intensity becomes greater).

Conversely, the values of E and E_h will become more negative when the concentration of the reductant increases relative to the oxidant (reducing intensity becomes greater).

Fermprobe® is a registered trademark of Broadley-James Corporation, Irvine, CA 92618 USA

Cutaway Views of the ORP Fermprobe® Double Junction Reference System

FERMPROBE

Isometric Overview

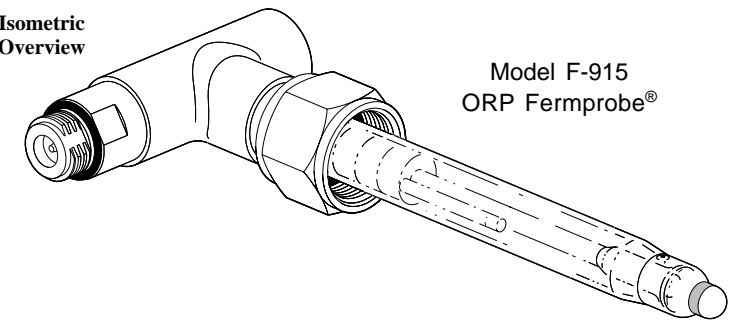

Model F-915 ORP Fermprobe®

Cutaway View and Detail

